



Ver. 202004



LG Electronics, Home appliance & Air solution company

56, Digital-ro 10-gil, Geumcheon-gu, Seoul, Republic of Korea (153-801)

www.lg.com

www.lgeaircon.com

LG HVAC SOLUTION

OIL-FREE MAGNETIC BEARING CENTRIFUGAL CHILLER

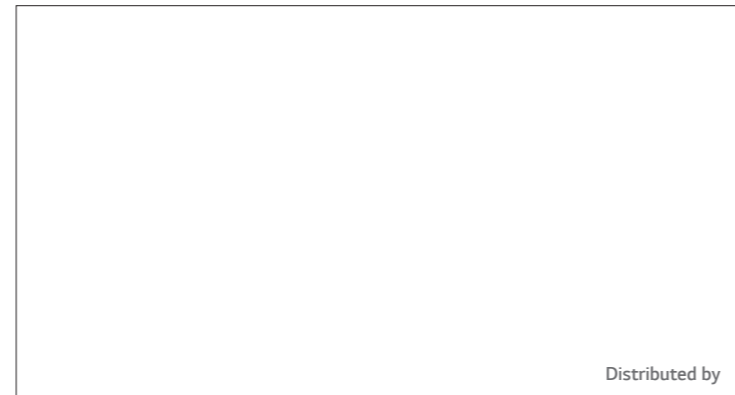

For continual product development, LG reserves the right to change specifications or designs without notice.

© 2020 LG Electronics. Printed in Korea. Apr. 2020

Distributed by



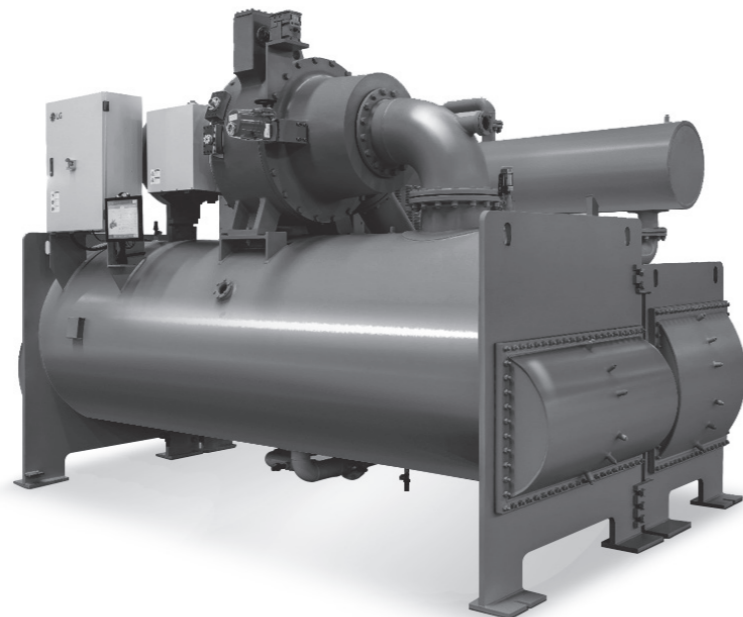
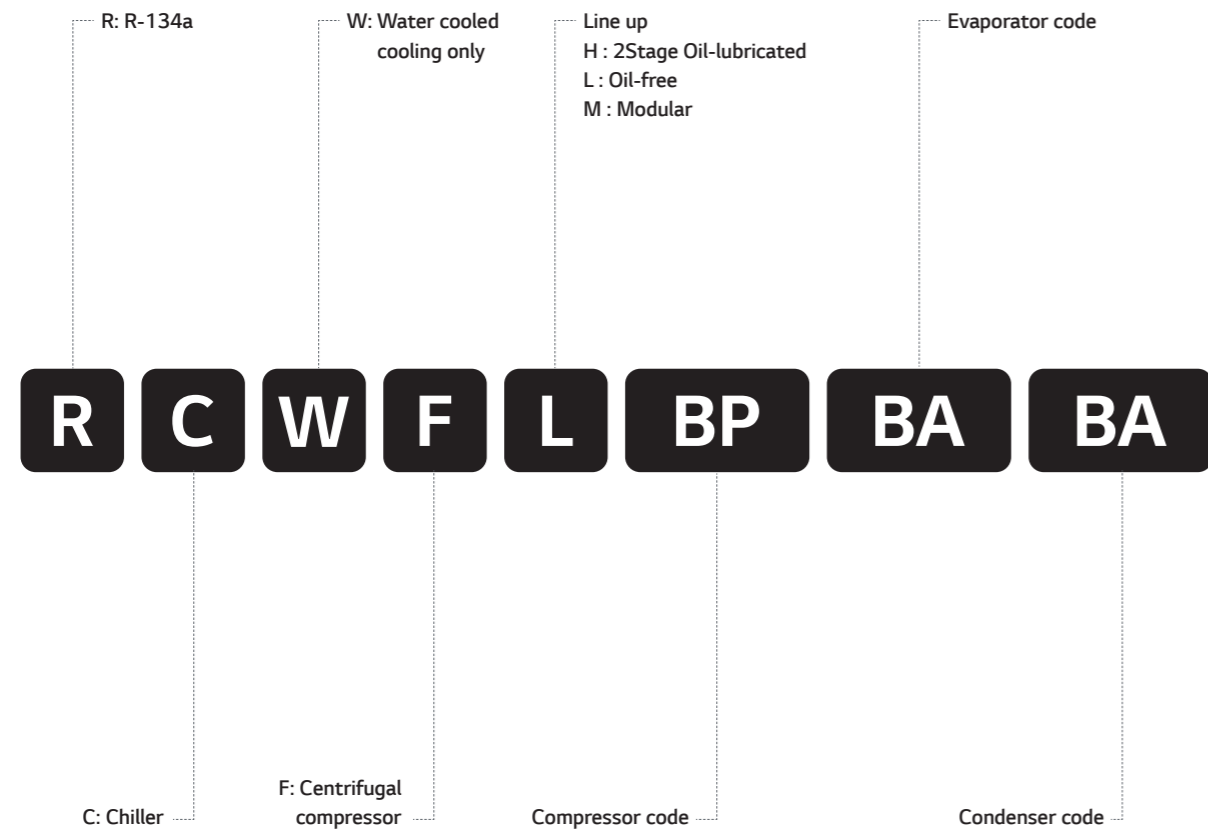

Contents

- 02 Nomenclature
- 03 Line up & Introduction
- 04 Features
- 11 Safety devices
- 12 Accessories and Options
- 13 Specification
- 15 Machine components
- 22 Field wiring
- 25 Piping & Wiring
- 26 Guide specification

Line up

		Unit: usRT					
		100	300	500	1,000	1,500	2,000
	Magnetic bearing	200RT		1 Comp.		1,100RT	
		600RT		2 Comp.		2,200RT	

* Please contact us if you want a specification other than the standard model.(Customized product available on request)

Innovative centrifugal chiller with a proven technology

LG has been trying to lead the HVAC industry for customers at the frontline of innovation. LG opens up new horizons of the centrifugal chiller with LG's own active magnetic bearing.

LG RCWFL(magnetic bearing type) chillers provide

- Chlorine-free HFC-134a refrigerant
- Easy maintenance and low maintenance cost with oil free technology
- High-precision chilled water leaving temperature control within $\pm 0.1^{\circ}\text{C}$

World-class efficiency



New solution for saving energy with Oil-free technology

The chiller using a magnetic bearing and high speed direct driven system developed by the technology of LG implements oil free technology.

Applying technologies of no contact magnetic bearing and direct connection structure between impeller and drive shaft is able to reduce lubrication losses by 2 ~ 3% as compared with conventional oil lubricated system, which increases energy efficiency. The installed Inlet guide vane(I.G.V) is able to secure stable operation range against surge.

Also, LG RCWFL magnetic bearing compressors are using 2 stage compression cycle with the flash type economizer from the existing LG centrifugal chiller(H Series) line up. The advantage of this cycle is reducing energy consumption of the 1st stage compressor at the both of full and partial load. Because flash gas generated from the expansion process

begins to get compressed from the intermediate pressure which is higher than evaporating pressure. Moreover, the refrigerant effect is increased as decreasing the quality of refrigerant at the inlet of evaporator.

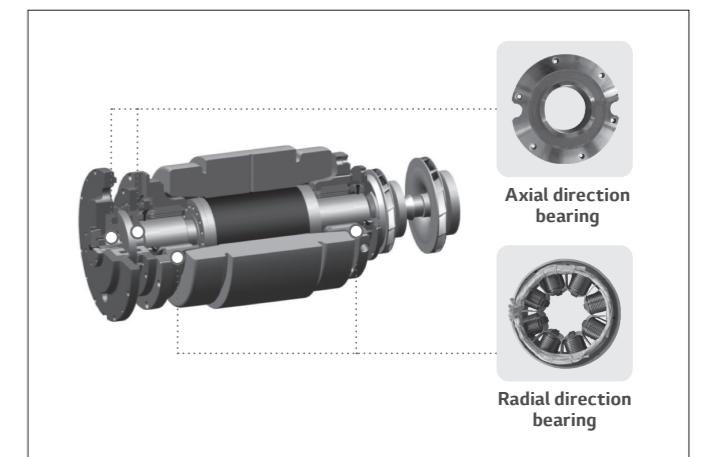

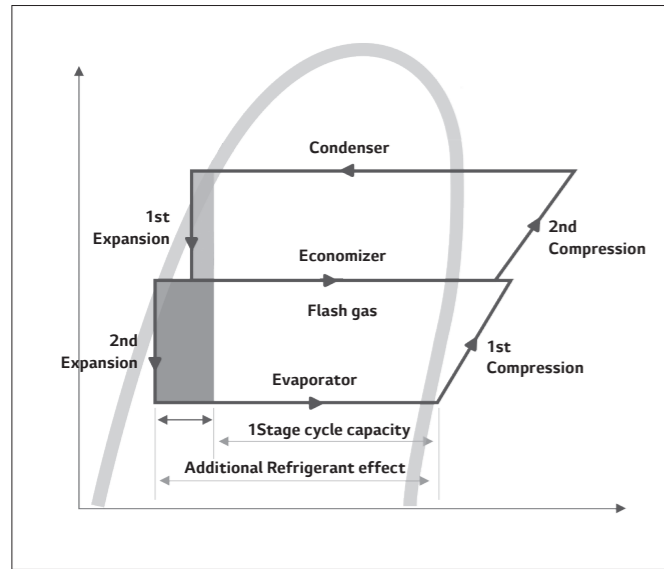

P-H Diagram for 2 stage compression with economizer

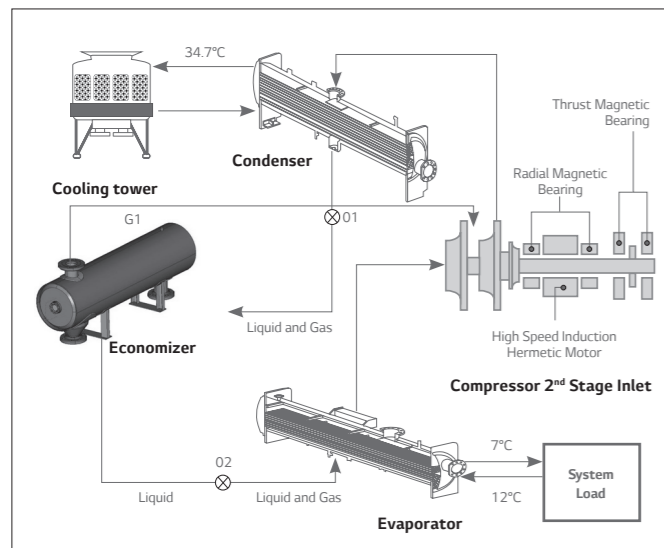

Refrigerant flow of 2 stage compression with economizer

LG RCWFL magnetic bearing chillers are applying Variable Speed Drive (VSD) as starting and capacity control device. Operation with VSD provides energy-efficient capacity adjustment at the partial load. In LG RCWFL magnetic bearing chillers, variable speed control combined with Inlet Guide Vane (IGV) or Discharge Gas Recirculation (DGR) allows operation closer to highest compressor efficiency and wide operation conditions. Vane of IGV is precisely controlled by modulated motor to smoothly adjust chilled water temperature when only cooling load is decreased at the certain fixed lift or head condition. The DGR uses impeller discharge gas creating the bypass flow to control refrigerant flow optimally at the compressor inlet, depending on the load. To minimize vibration at the high speed, the impeller undertakes dynamic balancing work. It also guarantees the overall reliability of the impellers by

undergoing the strength test, hardness test, non-destructive test for every impellers produced. Also, LG RCWFL magnetic bearing chiller can provide customized impeller and diffuser design to optimize performance at each high, middle and low lift application. So LG RCWFL magnetic bearing chiller can cover.

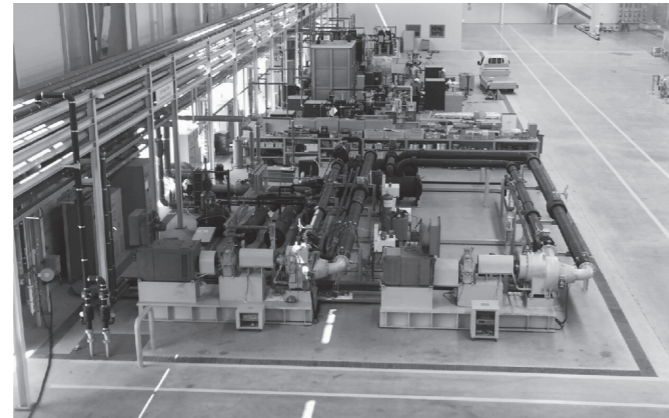

Compressor test facility

High reliability

Non-contact magnetic bearing supports rotor which directly connected with shaft and impellers, and it designed for the simple structure without any lubrication system such as oil pumps, reservoirs, heaters, cooler, filters and valves. Most of problems are directly or indirectly related with this lubrication system. With the removing of lubrication system, the reliability of RCWFL magnetic bearing chillers increases.

The reliability of core components; aerodynamic parts, heat exchangers, expansion system and main control system have been proven in many practical global sites as form of H-series during more than 5 years.

The compressor is operated by LG VSD to drive motor from zero to high speed rpm (~330 Hz). With built-in DC reactor, LG VSD can achieve low harmonic distortion (THDv < 5%) and higher power factor (> 0.95) at rated condition.

In case of sudden power failure, applied online UPS is being delivered power to the bearing and control system during maximum 30 min. Since the power is being supplied through UPS, there is no change in input or affected by noise, delivering high quality power.

Below are applied to protection logic for high reliability.

- Motor Over Current Limit and Protection
- Inverter Temperature High Protection
- Ground Fault Detection
- Voltage Low & High Protection



Built-in DC reactor

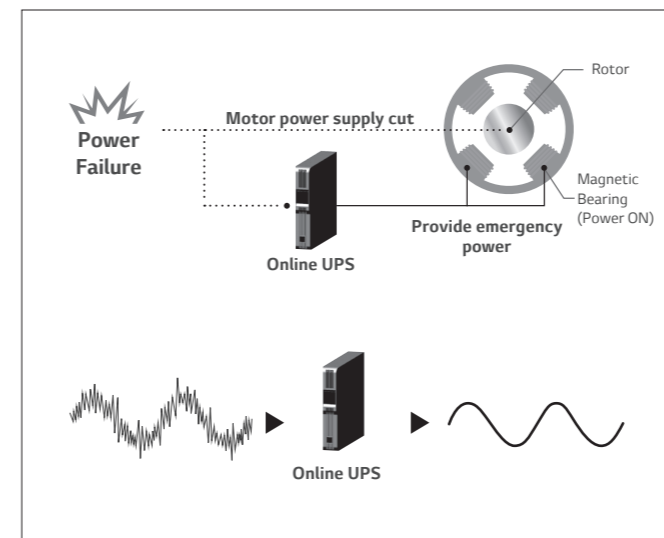

Online UPS system

LG Own oil-free technology

The rotor is levitated by well-controlled electromagnetic force which adjusts a distance between rotor and bearing surface with electric signal from precise proximity sensor based on LG mobile technology. Accurate sensors simultaneously detect shaft location and send signal to bearing controller for adjusting magnitude of electromagnetic field, correcting any deviations or perturbation within mere microns. By using this in-house developed/assembled compressor, LG can reduce service lead time and easily support customer on site condition.

Compact design

LG's RCWFL magnetic chiller is designed for less installation space and compact size with single large tonnage compressor and positive pressure refrigerant. It is favorable to small area that needs both remodeling and new buildings where is a minimized machine room can provide a valuable extra space and a cost saving of construction.

Quiet

An customer's common pain point with typical centrifugal chillers is the noise pollution that can disturb building occupants, neighbors and facilities operators in close proximity. LG's RCWFL magnetic chiller is achieved significant low noise by load base rotation control.

As a result, LG RCWFL magnetic bearing chiller sound level can reach 73 dBA*.

* Note: The above level indicate the noise values under the optimum operating conditions and may vary depending on the operating and environmental conditions.

Heat exchanger

Heat exchanger of LG RCWFL magnetic bearing chiller is composed of two shell type for easy separation into evaporator and condenser. The tubes are arranged so as to maximize the heat exchanging ability. It is also designed so that the refrigerant can be spread evenly on all tubes for the sake of surge prevention and the COP increase in part load operation. Efficiency increasing purpose sub cooler is adopted for the subcooling of the condensed refrigerant. A relief valve for an abnormal situation is at the upper part of the heat exchanger.

High Performance Tube

Heat transfer coefficients on inner surface are significantly enhanced by selecting optimal ridge size and angle without sacrificing pressure drop. In addition, Enhancement of heat transfer on outer surfaces are respectively designed and tested for easy condensation and evaporation.

Condenser

Condenser has a baffle to prevent direct impingement of high-velocity refrigerant gas on the tube surface and thus eliminate the related vibration and noise. Entering condenser water flows into sub-cooler from cooling tower and then flows through the upper part of condenser tube. This helps to lower the condensing temperature and thus reduce consumption of compressor power.

Flooded Evaporator (Standard)

"Flooded" shell and tube type evaporator having refrigerant in the shell and chilled water inside the tubes. The shell is of welded carbon steel construction with steel tube sheets and copper heat exchange tubes. Removable steel water boxes at both ends of the cooler allow tube cleaning without disturbing

the refrigerant circuit. Tubes are mechanically expanded into tube sheets with double grooves to ensure leak tight and trouble free operation.

Isolation valves of refrigerant filter(Options)

Isolation valves allow pump-down of refrigerant. These valves are installed for less service time and less expense. It is attached at the inlet and discharge of compressor and economizer port.

Pressure vessel(Options)

The evaporator and condenser can be provided with either ASME or PED pressure vessel codes certification.

Falling Film Evaporator(Options)

Falling film shell and tube type evaporator having refrigerant in the shell and chilled water inside the tubes. Advantage of this type evaporator is higher heat transfer performance and reduced refrigerant charge amount. LG patented distributor located on the top side of inside shell makes uniform flow of liquid refrigerant, and this flow goes down by gravity as a form of continuous film. The shell is of welded carbon steel construction with steel tube sheets and copper heat tubes. Removable steel water boxes at both ends of the evaporator allow tube cleaning without disturbing the refrigerant circuit. Tubes are mechanically expanded into tube sheets with double grooves to ensure leak tight and trouble free operation.

Expansion device and Economizer

The condensed refrigerant liquid passed the 1st expansion device enters the economizer which divides into refrigerant gas and liquid.

The refrigerant gas is mixed with mid-temperature, mid-pressure gas compressed in the 1st impeller. The refrigerant liquid goes through 2nd Expansion device to be taken into evaporator. The mid-temperature and mid-pressured gas between the 1st and the 2nd impeller become cool by mixing with the cool refrigerant gas supplied from economizer before sucked in to the 2nd impeller. As such, when the 2nd impeller discharge gas temperature is decreased by decreasing 1st impeller discharge gas, the power required by the compressor is decreased-increasing the cycle efficiency. The efficiency increase much higher than by the 1 Stage compressing method.

Quality Control

LG's entire quality control process from design to shipment is strictly managed by internal quality assurance principle and international standard, such as ISO 9001 & 14001. At the design phase, LG RCWFL series chillers are designed by 3-dimensional CAD tool to virtually lay out its parts and assemble each other. Both of experimental approach and computational analysis method are used to simulate and improve core parts efficiency such as aerodynamic and heat transfer performance.

All core components tested before assembly, and also all of sub vendors are strictly managed by LG quality policy and KS standards. The documentation of manufacturing, testing and quality assurance procedures are prepared to meet a customer's requirements.

Standards and Codes

- AHRI 550/590 - Water chilling packages using the vapor compression cycle.
- ANSI/ASHRAE 34 - Number designation and safety classification of refrigerants.
- ASME section VIII - Boiler and pressure vessel.
- CE - Conform to CE testing services for construction of chillers and provide CE listed mark.
- KGS AA111/112 – Facility / Technical / Inspection code for manufacture of high pressure gas refrigerators.
- KS B 6270 - Manufacturing, testing and quality assurance procedures based KS standard in centrifugal chillers.
- ANSI/ASHRAE Standard 15 safety code.
- Manufactured in an EN ISO 9001 accredited organization.
- ETL – Conforms to ANSI/UL STD 1995 certified to CAN/CSA STO C22.2.
- N.E.C. – National electrical code.
- OSHAS 18001 - Occupational safety and health act.



Unit performance test

LG has established one of the largest chiller testing facility in the world. Each LG chiller is thoroughly tested prior to shipment, and is delivered to the customer with test report including measured performance. Witness test is also available for all of lineup of RCWFL series, and also non-standard test such as zero-tolerance and constant cooling water are available as options.

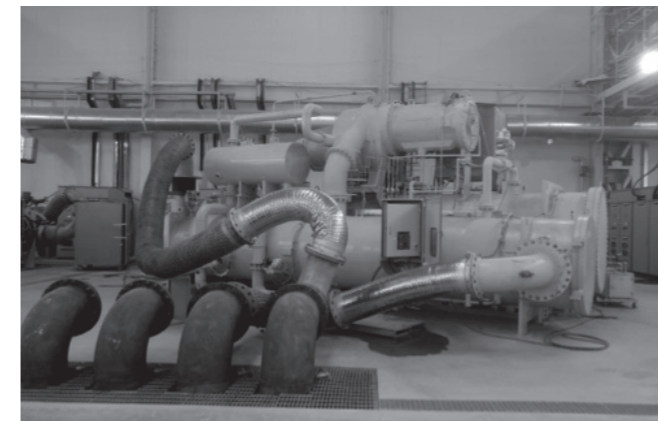

Unit performance test

Sustainable Refrigerant

LG RCWFL magnetic bearing chiller uses R-134a as refrigerant. LG chiller Division fully supports the further regulation agenda for HFCs in the amendment of the Montreal Protocol. Furthermore, we are studying and preparing next generation chillers compatible with refrigerants which have zero ODP and low GWP to satisfy social demands for protecting environment in near future. In conjunction with new chiller development policy, we will continue to supply products to market with R-134a until there is a new policy that supports switching to a new refrigerant that has a better environmental friendly characteristic.

Microprocessor-based controls

LG's Microprocessor-based controller, LGC-X30 enables the user to monitor and control the chiller with high-class accuracy and confidence. The exclusively designed algorithm allows the optimized operation.

LGC- X30 controller is ready for multi-language support; Chinese, English and Korean.

LGC- X30 has 100% H/ W compatibility and freely interfaces with other LG machines Max 255 units of LG chiller can be linked together and controlled through only 1 protocol converter.

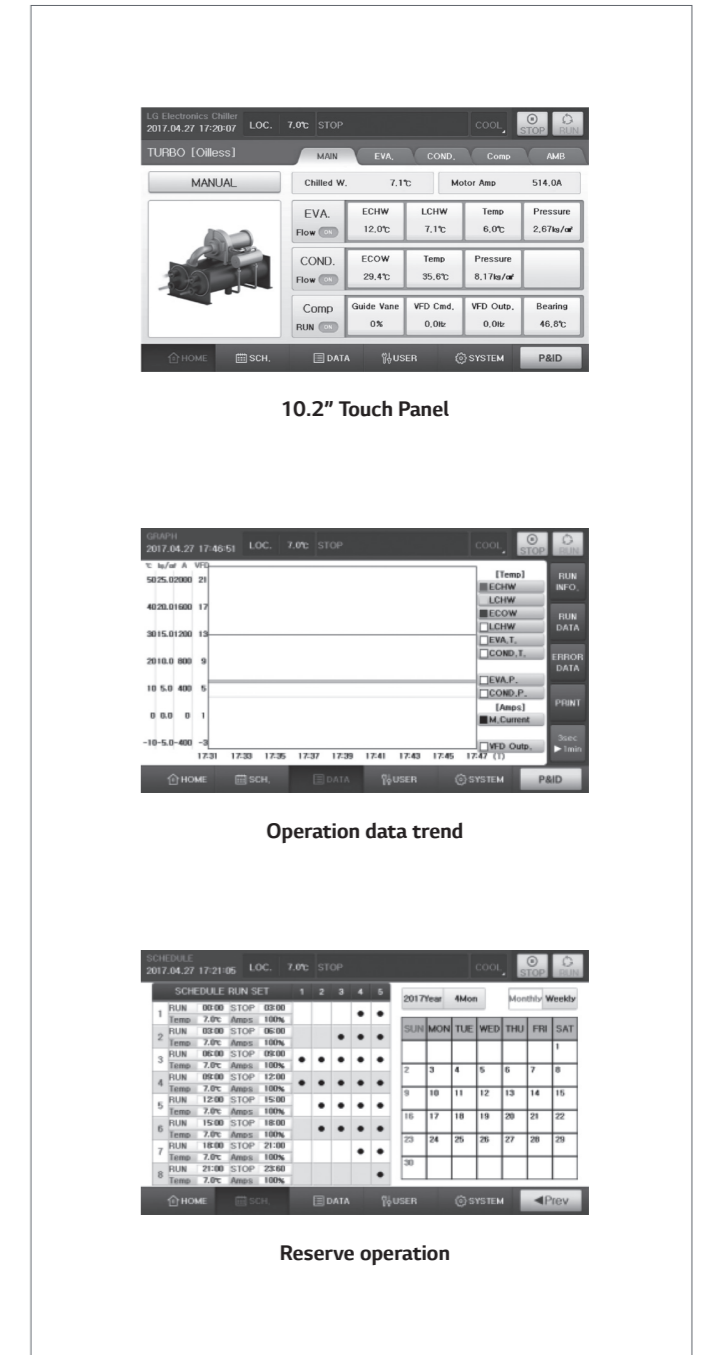

10.2" Touch Panel

Operation data trend

Reserve operation



State of evaporator



State of condenser

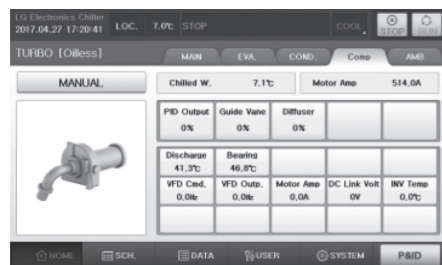

State of compressor

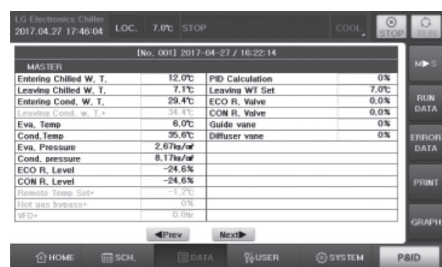

Operation history

Microprocessor controls

The unit controller is factory mounted, wired and tested before shipment. And a built-in printer, BACnet™, MODBUS™ protocol converter module and Modem are equipped as an option.

Safety control

The all safety control inputs and, if required, shuts down the chiller or limits the guide vanes to protect the chiller from possible damage from and of the following conditions:

- High bearing temperature
- High motor winding temperature
- High discharge temperature
- Low cooler refrigerant temperature/pressure
- Condenser high pressure or low pressure
- Inadequate water cooler and condenser flow
- Excessive motor acceleration time
- Excessive starter transition time
- Lack of motor current signal
- Excessive motor amps
- Excessive compressor surge
- Temperature and transducer faults
- Soft start system
- Soft stop system
- Control circuit fuse
- Control module fuse
- Safety relief valve

Main menu indications(Control center)

- Run Mode Set
- User Set
- Manual Control
- Schedule Set
- Service Menu
- Run Data Check
- Error Data Check
- Pager Mode Set
- System Menu
- Bright Control

Basic display items

- Chilled water inlet & outlet temperatures(°C)
- Cooling water inlet & outlet temperatures(°C)
- Compressor discharge temperature(°C)
- Compressor bearing temperature(°C)
- Operating Frequency(Hz)
- DC Link Voltage(Vdc)
- VSD input current(A)
- VSD output current(A)
- VSD temp(°C)

- Motor windings(R.S.T) temperatures(°C)
- Evaporator pressure(kg/cm²)
- Condenser pressure(kg/cm²)
- Amperes(A)
- Voltages(V)
- Watts(kW)
- Chilled water flow(m³/h)fR
- Cooling water flow(m³/h)fR
- Vane openings(%)
- Remote setting temperature(°C)
- Evaporator temperature(°C)
- Condenser temperature(°C)
- Differential pressure of oil(kg/cm²)
- Hot-gas valve output(%)
- Frequency of cooling tower fan inverter(Hz)
- PID output(%)
- Control output(%)
- Real setting value(°C)
- These items are optional.

User settings

- Chilled outlet temperature(°C)
- Compressor current limit(%)
- Guide vane high limit(%)
- Cooling mode P & I & D(°C, sec, sec)
- Hot-gas valve- Vane %(%)
- Hot-gas valve max.(%)
- Hot-gas valve min.(%)
- Chilled water brine temperature(°C)
- Cooling tower fan RUN(°C)
- Cooling tower fan STOP(°C)
- Cooling tower fan STEP(°C)
- Cooling tower fan delay(sec)
- Cooling water inlet temperature(°C)
- Cooling tower fan P & I & D(°C, sec, sec.)
- Operational data log time(sec.)
- Year
- Month
- Date
- Week
- Hour
- Minute
- Second
- LCD light on time(sec.)

Main menu indications(Control center)

- Run Mode Set
- User Set
- Manual Control
- Schedule Set
- Service Menu
- Run Data Check
- Error Data Check
- Pager Mode Set
- System Menu
- Bright Control

Variable Speed Driver

- VSD Controller : VSD Panel Control(Communication/Motor Speed Control)
- AC / DC Reactor : Built-in Harmonic Filter
- UPS : Power supply to magnetic bearing and work as a back up battery
- Rectifier Power Module : AC To DC Converter, DC power conversion for inverter variable frequency control
- DC Link Capacitor : Stable supply of DC converted power to inverter power module
- Inverter Power Module : Motor rotation frequency control

Magnetic Bearing Controller

- Levitation control: Controls levitation based on operation load UPS maintains stable levitation control even at power outage situation.

Control sequence

Start

The chiller Starts to run by pressing the RUN-key on the control center of unit controller, the key must be pressed for 2 seconds as a minimal. During the manual operation, RUN type must be set as "local mode" second start-up will only activate 30 minutes(Expiration of re-start prevention timer) after normal-start or 3 minutes(expiration of starting oil pump circulation timer) after auto-stop in order to protect compressor.

Firstly, the chilled water pump is energized, and then the cooling water pump is energized 5 seconds later. And the chiller will proceed to next sequence only after chilled water and cooling water flows reach the limits. If the chilled water temperature is 2°C less than setting temperature, only the

chilled water pump will run.

Once the chiller started, the compressor starts from the soft-loading mode to open the vane slowly in order to prevent rapid increase of power consumption. Then the capacity control follows. When the troubles occur after compressor energized, the compressor stops, and the alarm lamp is on, and the shutdown status is displayed on the touch panel, and also shutdown information is recorded into the RAM of controller.

Stop

The chiller stops under one of the following events:

- The Stop button is pressed for at least 2 seconds or the remote-stop signal is delivered to the controller.
- Auto-stop at " Setting temperature - 2°C "
- Time schedule is stop-mode
- Alarm states

During the stop process, firstly the compressor is forced to stop. The guide vane is brought to the closed position. The oil pump and chilled water pump stop 300 seconds after the compressor stops. The cooling water pump will stop. And 3minutes of starting oil pump circulation timer will count down.

If the stop button is pressed or remote-stop signal is delivered, the guide vanes will close. And the chiller will stop, if the vane full-close limit switch is closed or the vane opening is less than 10% or 4 minutes passed from that the vane starts to close.

Re-start

Restart is activated only after the followings;

- After expiration of re-start prevention timer(30 minutes)
- If the chiller stops due to a safe-stop, the reset button must be pressed before restarting the chiller. increase of power consumption. Then the capacity control follows. If any trouble occurs after compressor is energized, the compressor stops, and the alarm lamp is on, and the shutdown status is displayed on the LCD, and also shutdown information is recorded into the RAM of controller.

Various interface solutions

Using industrial standard protocol converters, the chiller can be interfaced with BAS(Building Automation System).

The remote monitoring and control of the chillers is possible via BACnet™/ Ethernet, BACnet™/IP, MODBUS™, Modem or RS-232C/RS-485.

Advanced PID control

The advanced algorithm provides an optimum control during the chiller starts, stops and even normal-operation. The advanced PID control minimizes the overshoot and undershoot during the chiller starts and normal operation, and also enables accurate and quick response to temperature control.

Chilled water temperature reset

The chilled water temperature can be reset locally or remotely to readjust the chilled water outlet temperature and save energy.

Operation scheduling

The user can program the chiller operation schedule to run and stop the chiller automatically during the absence of the operator.

Soft loading

At the start-up, the vane opening is controlled with gradual slow- open to prevent surge, finally to protect compressor. This control lasts until the chilled water temperature reaches the target value.

Preventive control

The preventative control is executed before abnormal-stop point and so unnecessary chiller-stops can be minimized.

Various interface solutions

Using industrial standard protocol converters, the chiller can be interfaced with BAS(Building Automation System).

The remote monitoring and control of the chillers is possible via BACnet™/ Ethernet, BACnet™/IP, MODBUS™, Modem or RS-232C/RS-485.

Safety devices

For the sake of safe operation and the protection of the chiller, safety devices are ready as the next table.

No.	Safety Devices	Installation Location	Measurement Item	Description	Quantity
1	Chilled Water Temperature Low	Chilled water inlet nozzle	Chilled water inlet temperature	Chiller stops operation if the chilled water outlet temperature below 3°C to prevent freezing of the chilled water. Do not change this set value.	1
2	Evaporator Pressure Low (Temperature Low)	Evaporator shell	Vaporizing pressure (Temp.)	If the pressure inside of evaporator reaches below of the following table, then the chiller stops operation. Standard set value 1.95kg/cm ²	1
3	Condenser Pressure High (Temperature High)	Condenser shell	Condensing pressure (Temperature)	If the pressure inside of condenser reaches above of the following table, then the chiller stops operation. Standard setting value 10.00kg/cm ²	1
4	Motor Temperature High	Motor coil	Motor coil temperature	To prevent the motor of the compressor, temperature sensors were installed on each phase of coil and when the temperature exceeds 90°C, the chiller stops operation.	3
5	Compressor Temperature High	Compressor outlet	Compressor discharge temperature	If the discharging gas temperature of the compressor exceeds over 70°C, the chiller stops operation.	1
6	Bearing Temperature High	Thrust bearing	Bearing temperature	Temperature sensor is installed on the thrust bearing that holds the impeller's thrust. Chiller will stop operation if the temperature exceeds 85°C.	1
7	Inverter Overcurrent	VSD	Current sensor	Stop the chiller if rated current is above 140% to protect the compressor	3
8	DC-Link Low Voltage/Over Voltage	VSD	Voltage sensor	Stop the chiller if rated voltage is below 70% or above 140% to protect the inverter	1
9	Inverter Heat Sink(High Temp.)	VSD	Heat sink temperature sensor	Stop the chiller if temperature is above 65°C to protect the inverter	3
10	M,I,T Bearing Trajectory Error	MBC	M,I,T Bearing gap sensor	Stop the chiller if bearing trajectory is maintained at back up clearance of 50% to protect the compressor	3
11	M,I,T Bearing Temperature (High Temp.)	MBC	M,I,T Bearing temperature sensor	Stop the chiller if bearing temperature is maintained at 95°C for bearing stability	3
10	Chilled Water Pump Abnormal	Chilled water header	Chilled water head loss	The chiller will stop if the head loss of the chilled water flow passing through the evaporator tubes decreases so much that the loss head becomes lower than the standard.	1
11	Cooling Water Pump Abnormal	Chilled water header	Cooling water head loss	The chiller will stop if the head loss of the cooling water flow passing through the condenser tubes decreases so much that the loss head becomes lower than the standard.	1
12	Current Limiting Function	Control panel	Current	It is a controlling function of motor amps that can be set freely in the range of 40 ~ 100% to adjust the current load to the motor of compressor.	1
13	Moisture Indicator	Refrigerant supply pipe	Moisture in the refrigerant	The moisture indicator changes the color depending on the amount of moisture in the refrigerant. When there is no moisture it will be green, but if not it will be yellow. It is the time to change into a new filter if you can see the yellow color.	1
14	Relief Valve	Evaporator & condenser shell	Relief valves	To prevent the accident by unexpected fire, and so on which can cause pressure increase in the chiller, the relief valve will be operated and exhaust the refrigerant into the air if the pressure exceeds more than the standard. If the chiller is used in a closed environment, please install a pipe that starts from the relief valve to the outer air.	1
15	Vane Full Close Interlock	Vane motor	Operability of temperature sensors	To minimize the starting current, it is a function to enable the compressor to operate only after full close of the guide vane installed at the inlet of the impeller.	1
16	Temperature Sensor Abnormal	6 locations including chilled water nozzle	Each temperature sensor	It alarms when temperature sensor is not connected or due to the sensor's own flaw.	1
17	Pressure Sensor Abnormal	4 locations including evaporator shell	Each pressure sensor	It alarms when pressure sensor is not connected or due to the sensor's own flaw.	1
18	Overload relay	Control panel	Current	If overload is imposed on compressor motor or oil pump motor, it stops the motor.	1
19	Hot Gas Bypass Valve	Evaporator shell, Condenser shell	Inlet guide vane / Hot gas bypass valve	It prevents frequent start ups at low load, and hot gas bypass valve opens proportionally when vane becomes 30% or lower. At this time, hot refrigerant gas of condenser goes to evaporator and makes certain chiller load to prevent surge and to prevent frequent startup stop of the chiller.	1

Oil-free Magnetic chiller standard summary

Items	Standard	Option
Power Supply	<input type="checkbox"/> 380~460V	<input type="checkbox"/> 380V <input type="checkbox"/> 440V <input type="checkbox"/> etc()
Hertz	<input type="checkbox"/> 50Hz, 60Hz	
Compressor	Bearing temperature sensor	<input type="checkbox"/> Yes(Dual type)
	Motor coil temperature sensor	<input type="checkbox"/> RTD (2stage)
	Hot gas by pass	<input type="checkbox"/> Standard <input type="checkbox"/> N/A
	Communication	<input type="checkbox"/> Modbus <input type="checkbox"/> BACnet <input type="checkbox"/> TCP/IP <input type="checkbox"/> etc()
Control Panel	Momentary Power Loss Compensation	<input type="checkbox"/> N/A <input type="checkbox"/> Yes
	Factory Wiring	<input type="checkbox"/> Duct & Flexible <input type="checkbox"/> Open Wiring
Starter Panel	Starter type	<input type="checkbox"/> Inverter(VSD)
	Circuit Breaker Low V(380V/440V)	<input type="checkbox"/> MCCB <input type="checkbox"/> ACB
	Power Access	<input type="checkbox"/> From the Top <input type="checkbox"/> From the side of top
EVAP.	Integrating Watt-meter	<input type="checkbox"/> N/A <input type="checkbox"/> Yes <input type="checkbox"/> etc()
	Waterbox type	<input type="checkbox"/> NIH(Rectangle) <input type="checkbox"/> NIH(Circle) <input type="checkbox"/> Marine <input type="checkbox"/> Marine + hinged
	Waterbox Pressure	<input type="checkbox"/> 150psig(10kg/cm ²) <input type="checkbox"/> 230psig(16kg/cm ²) <input type="checkbox"/> 300psig(20kg/cm ²)
	Waterbox Coating	<input type="checkbox"/> Standard <input type="checkbox"/> Epoxy Coating <input type="checkbox"/> Ceramic Coating
COND.	Nozzle direction	<input type="checkbox"/> Magnetic bearing chiller <input type="checkbox"/> Air bearing chiller(Front of Control panel)
	Nozzle Arrangement(inlet)	<input type="checkbox"/> Motor End <input type="checkbox"/> Compressor End <input type="checkbox"/> LEFT <input type="checkbox"/> RIGHT
	Nozzle Arrangement(outlet)	<input type="checkbox"/> Motor End <input type="checkbox"/> Compressor End <input type="checkbox"/> LEFT <input type="checkbox"/> RIGHT
	Nozzle type	<input type="checkbox"/> ANSI-Flange <input type="checkbox"/> ANSI-Victaulic(AGS) <input type="checkbox"/> ANSI-Victaulic(OGS)
	Waterbox type	<input type="checkbox"/> NIH-Rectangle <input type="checkbox"/> NIH-Circle <input type="checkbox"/> Marine <input type="checkbox"/> Marine + hinged
COND.	Waterbox Pressure	<input type="checkbox"/> 150psig(10kg/cm ²) <input type="checkbox"/> 230psig(16kg/cm ²) <input type="checkbox"/> 300psig(20kg/cm ²)
	Waterbox Coating	<input type="checkbox"/> Standard <input type="checkbox"/> Epoxy Coating <input type="checkbox"/> Ceramic Coating
	Nozzle direction	<input type="checkbox"/> Magnetic bearing chiller <input type="checkbox"/> Air bearing chiller(Front of Control panel)
	Nozzle Arrangement(inlet)	<input type="checkbox"/> Motor End <input type="checkbox"/> Compressor End <input type="checkbox"/> LEFT <input type="checkbox"/> RIGHT
COND.	Nozzle Arrangement(outlet)	<input type="checkbox"/> Motor End <input type="checkbox"/> Compressor End <input type="checkbox"/> LEFT <input type="checkbox"/> RIGHT
	Nozzle type	<input type="checkbox"/> ANSI-Flange <input type="checkbox"/> ANSI-Victaulic(AGS) <input type="checkbox"/> ANSI-Victaulic(OGS)
	Flow Proof Type	<input type="checkbox"/> N/A <input type="checkbox"/> DP Switch
	Refrigerant R134a Charge	<input type="checkbox"/> Separated Shipping <input type="checkbox"/> Customer supplied <input type="checkbox"/> Factory Charged
	Packing	<input type="checkbox"/> Shrink film <input type="checkbox"/> Wooden packing
Insulation	<input type="checkbox"/> N/A <input type="checkbox"/> Yes	
Sound attenuator	<input type="checkbox"/> N/A <input type="checkbox"/> Discharge Only <input type="checkbox"/> Condenser + Discharge	
Isolation	<input type="checkbox"/> Neoprene PAD <input type="checkbox"/> Spring 1Inch <input type="checkbox"/> Spring 2Inch <input type="checkbox"/> Spring Rubber Pad	
Anchor Bolt for Foundation	<input type="checkbox"/> N/A <input type="checkbox"/> Yes(Set-Anchor) <input type="checkbox"/> Yes(L-TYPE(M20*250L))	
Automatic expansion V/V(2stage)	<input type="checkbox"/> Standard <input type="checkbox"/> Auto Expansion V/V 2EA, Level Sensor 2EA	
Counter Pipe Flange	<input type="checkbox"/> N/A <input type="checkbox"/> Yes	
Certification	<input type="checkbox"/> Standard(KGS) <input type="checkbox"/> ASME VIII Only <input type="checkbox"/> CE(PED) <input type="checkbox"/> PED <input type="checkbox"/> (C)UL(ETL)	
Factory Performance Test & Process inspec.	<input type="checkbox"/> N/A <input type="checkbox"/> Report Only <input type="checkbox"/> Customer witness <input type="checkbox"/> Process inspection	
Partial Load Test	<input type="checkbox"/> N/A <input type="checkbox"/> 75% <input type="checkbox"/> 50% <input type="checkbox"/> 25%	
Operating Training	<input type="checkbox"/> N/A <input type="checkbox"/> Yes	
Warranty-Compressor	<input type="checkbox"/> 1yr <input type="checkbox"/> etc()	
Warranty-Ass'y	<input type="checkbox"/> 1yr <input type="checkbox"/> etc()	
Labor warranty	<input type="checkbox"/> N/A <input type="checkbox"/> etc()	

Standard specification

- 1) Starter Panel(Supplied by factory)
- Starter type : Inverter(VSD), Power Access : Unit mounted, International protection : IP4X, Door Type : 1Door
- 2) Control Panel
Controller : Micom, Communication : Modbus, International protection : IP41, Display : 10.2 inch touch screen
- 3) Factory Wiring : Duct & Flexible
- 4) Color : Dawn Gray(Starter/Control Panel : Warm Gray)
- 5) Standard provide Internal Inspection Lamp and Emergency stop switch
- 6) Flow proof type : DP Switch(Evaporator)

Oil-free Magnetic chiller (200~700usRT)

Model name		RCWFLAL	RCWFLAM	RCWFLAN	RCWFLAP	RCWFLBM	RCWFLBN	RCWFLBP	RCWFLCM	RCWFLCN	RCWFLCP	
Cooling Capacity	usRT	200	250	280	300	400	450	500	550	600	700	
	kW	703	879	985	1,055	1,407	1,582	1,758	1,934	2,110	2,461	
Shipping Weight	kg	4,929	5,039	5,093	5,147	6,169	6,279	6,441	8,712	8,712	8,929	
operating Weight	kg	5,567	5,722	5,800	5,877	7,200	7,356	7,584	10,098	10,098	10,407	
Compressor	Type	* C MAGNETIC BEARING										
	No.	m ³ /h 1 Compressor										
Motor Power	kW	234	234	234	234	390	390	390	543	543	543	
Power Supply	Hz	50/60 Hz										
Condenser	Nozzle Connection Size	A	150	150	150	150	200	200	200	200	250	250
	Rated Flow Rate	m ³ /h	146	182	203	217	285	319	354	392	427	497
	Pressure Drop	mH ₂ O	5	5	5	5	5	5	5	5	5	5
	Pass	EA	2	2	2	2	2	2	2	2	2	2
Evaporator	Nozzle Connection Size	A	150	150	150	150	200	200	200	200	250	250
	Rated Flow Rate	m ³ /h	121	151	169	181	242	272	302	333	363	423
	Pressure Drop	mH ₂ O	3	4	4	4	3	4	4	4	3	4
	Pass	EA	2	2	2	2	2	2	2	2	2	2
Dimension	Length	mm	3,500	3,500	3,500	3,500	3,500	3,500	3,500	3,500	3,500	3,500
	Width	mm	2,225	2,225	2,225	2,225	2,250	2,250	2,250	2,885	2,885	2,885
	Height	mm	1,890	1,890	1,890	1,890	2,143	2,143	2,143	2,325	2,325	2,325

Precautions

- LG centrifugal chillers are a combination of compressors, condensers, and evaporators, enabling various model deployment and providing other specifications. In this case, please contact LG Electronics.
- To improve the performance, some specification can be changed without notice.
- 1 usRT = 3,024 kcal / h
- Chilled inlet / outlet temperature : 12 °C / 7 °C
- Cooling inlet / outlet temperature : 32 °C / 37 °C

Oil-free Magnetic chiller (800~2,200usRT)

Model name		RCWFLDM	RCWFLDN	RCWFLDP	RCWFLDQ	RCWFLAW	RCWFLBW	RCWFLCW	RCWFLDW	RCWFLDX	
Cooling Capacity	usRT	800	900	1,000	1,100	600	1,000	1,400	2,000	2,200	
	kW	2,813	3,165	3,516	3,868	2,110	3,516	4,923	7,033	7,736	
Shipping Weight	kg	9,483	9,712	11,214	11,514	11,900	14,100	19,600	30,300	31,000	
operating Weight	kg	11,224	11,549	13,423	13,723	13,200	17,400	23,100	35,400	36,000	
Compressor	Type	MAGNETIC BEARING									
	No.	1 Compressor				2 Compressor					
Motor Power	kW	775	775	775	775	234 x 2	390 x 2	543 x 2	775 x 2	775 x 2	
Power Supply	Hz	50/60 Hz									
Condenser	Nozzle Connection Size	A	250	300	300	300	250	300	350	450	450
	Rated Flow Rate	m ³ /h	568	639	709	777	429	700	982	1,401	1,548
	Pressure Drop	mH ₂ O	8	7	7	8	10	3	4	5	6
	Pass	EA	2	2	2	2	2	2	2	2	2
Evaporator	Nozzle Connection Size	A	250	300	300	300	250	300	350	450	450
	Rated Flow Rate	m ³ /h	484	544	605	665	363	605	847	1,210	1,331
	Pressure Drop	mH ₂ O	5	5	5	6	9	2	3	4	4
	Pass	EA	2	2	2	2	2	2	2	2	2
Dimension	Length	mm	4,150	4,150	4,150	4,150	4,986	5,500	6,500	7,226	7,226
	Width	mm	2,835	2,835	2,835	2,835	2,267	2,309	2,961	2,700	2,700
	Height	mm	2,899	2,899	2,899	2,899	2,100	2,225	2,694	2,970	2,970

Precautions

- LG centrifugal chillers are a combination of compressors, condensers, and evaporators, enabling various model deployment and providing other specifications. In this case, please contact LG Electronics.
- To improve the performance, some specification can be changed without notice.
- 1 usRT = 3,024 kcal/h
- Chilled inlet / outlet temperature : 12 °C / 7 °C
- Cooling inlet / outlet temperature : 32 °C / 37 °C

VSD Starter data

Model	250kW	350kW	500kW	750kW
Max. Output Power(kw)	250	350	500	750
Efficiency(%)	96.5	96.5	96.5	96.5
Frequency(Max)	330	260	220	180
Dimension	W(mm)	1,250	1,250	1,580
	H(mm)	850	850	910
	D(mm)	550	550	1,087
Operation Ambient Temperature(°C)	40			
Remark	Humidity, 95% non-condensing			

For continual product development, LG reserves the right to change specifications or designs without notice

Machine outline

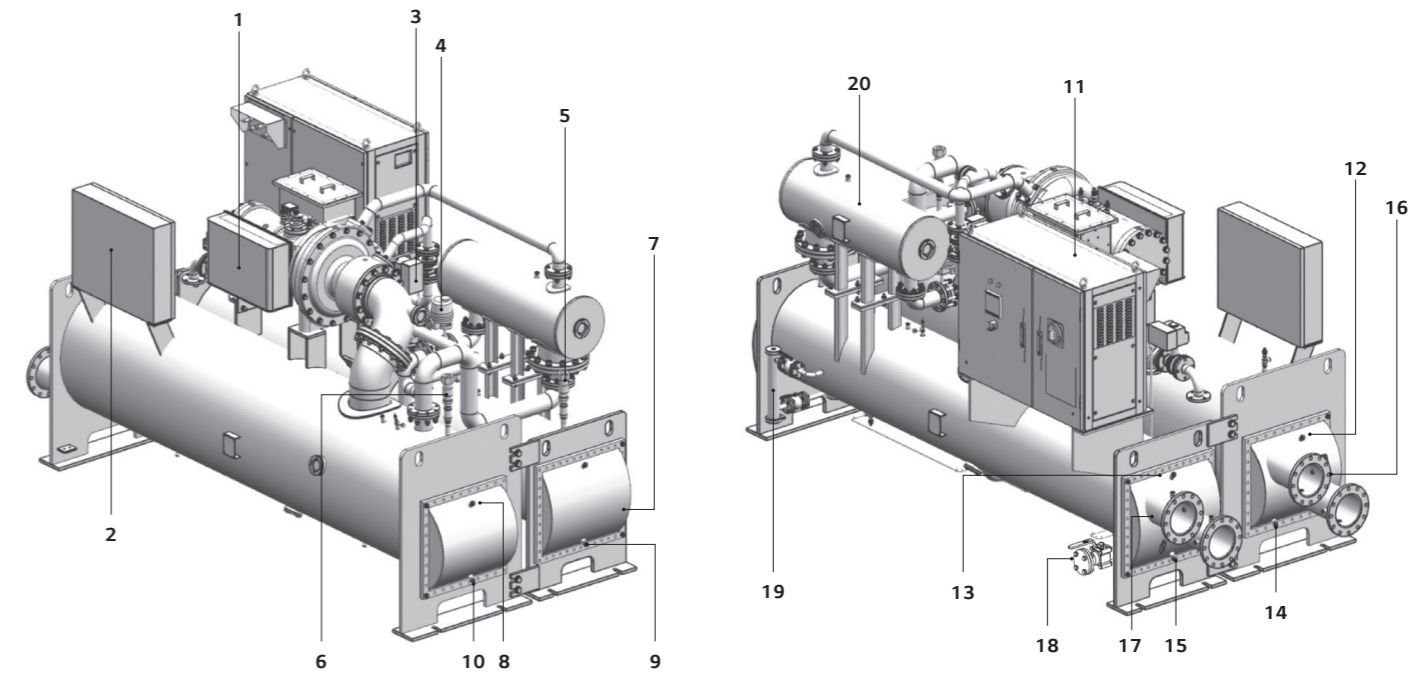

Front view

1. MBC(Magnetic Bearing Controller)
2. Control Panel
3. DGR(Discharge Gas Recirculation) valve
4. Condenser level control valve
5. Condenser safety valve
6. Evaporator safety valve
7. Air vent(Cooling water)
8. Air vent(Chilled water)
9. Drain(Cooling water)
10. Drain(Chilled water)

Rear view

11. VSD(Variable Speed Driver)
12. Air vent(Chilled water)
13. Air vent(Cooling water)
14. Drain(Chilled water)
15. Drain(Cooling water)
16. Water box(Chilled water)
17. Water box(Cooling water)
18. Flange for vacuum(For service)
19. Condenser level sensor
20. Economizer(Optional)

1 Compressor

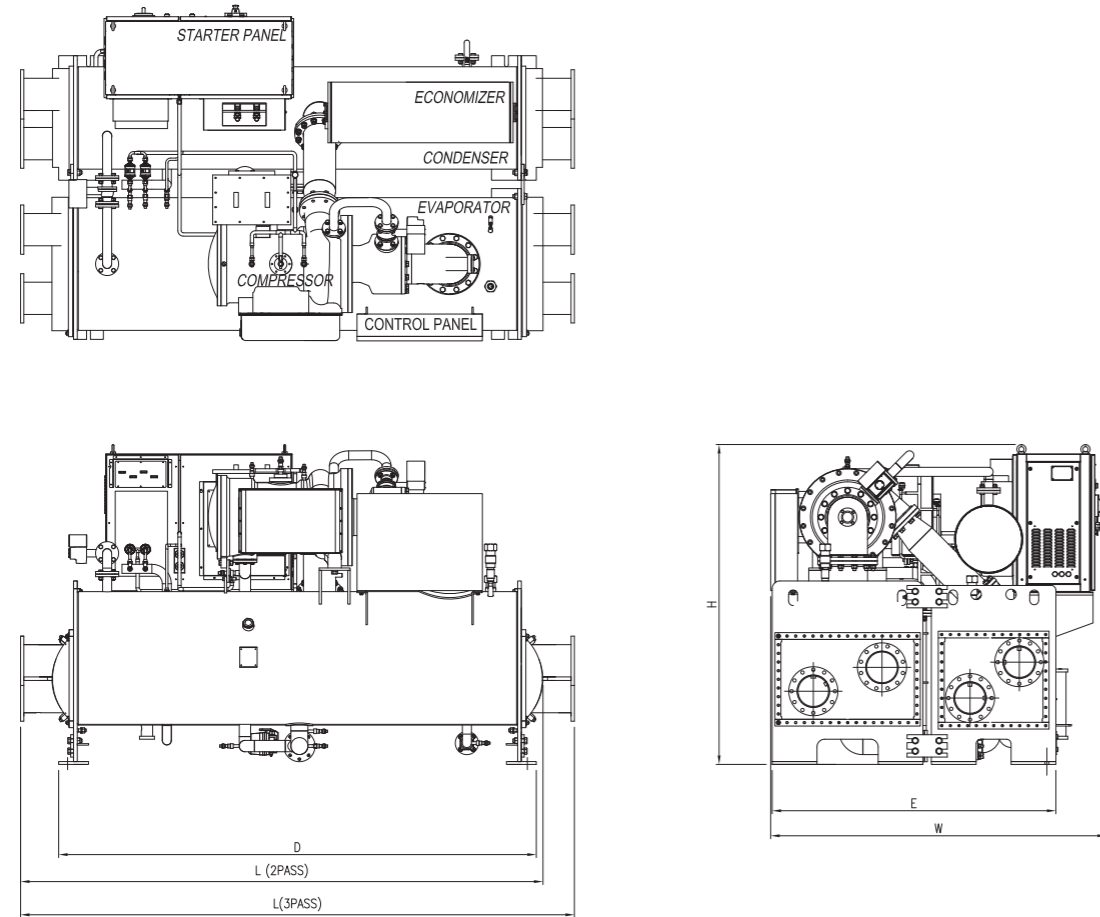

Unit : mm

Model	Outline Dimension				Base Dimension		Water Flow Pass(A)		
	L		W	H	D	E	Eva	Cond	
	2pass	3pass					2pass	2pass	
RCWFL	AL-AP	3,500	3,710	2,225	1,890	3,200	1,617	150	150
	BM-BP	3,500	3,710	2,250	2,143	3,200	1,900	200	200
	CM-CP	3,500	3,710	2,885	2,325	3,200	2,072	250	250
	DM-DQ	4,150	4,360	2,835	2,899	3,850	2,392	300	300

Note

- The height is measured from the bottom of the heat exchanger.
This value does not include the height of the foundation and the vibration-absorbing pedestal.
- All of the chilled water and cooling water connection flanges are of ANSI 150lb.
- The water pipe facility shall be designed to prevent external force to the chiller.
- The minimum spaces shall be provided around the chiller as follow :
 - Length direction of the chiller: 1,500 mm-2,000mm
 - One of the left and the right side shall be provided with space for Tube replacement.(3,700-6,700mm)
 - Control panel : 1,500mm
 - Inverter panel: 2,000mm
 - Height : 1,000mm
- All specifications are subject to change without notice.

2 Compressor

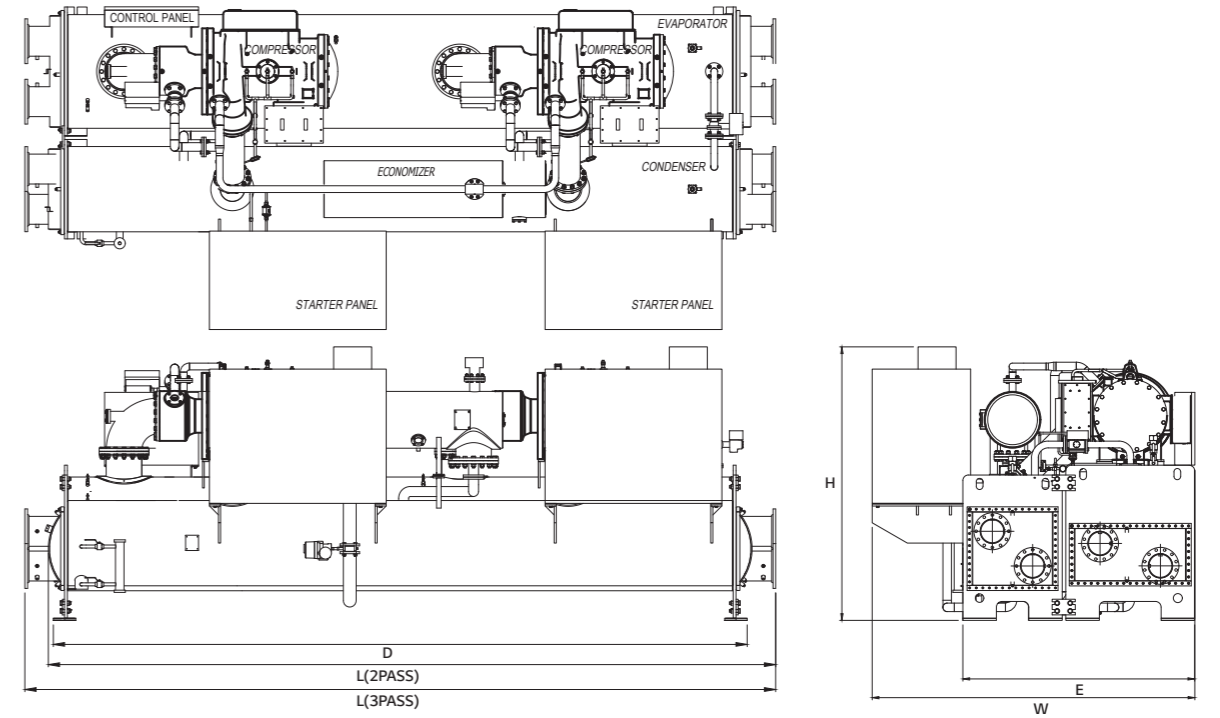

Unit : mm

Model	Outline Dimension				Base Dimension		Water Flow Pass(A)		
	L		W	H	D	E	Eva	Cond	
	2pass	3pass					2pass	2pass	
RCWFL	AR-AW	4,986	5,201	2,267	2,100	4,680	1,900	250	250
	BT-BW	5,500	5,710	2,309	2,225	5,200	2,072	300	300
	CT-CW	6,500	6,710	2,961	2,694	6,200	2,392	350	350
	DT-DX	7,226	7,500	2,700	2,970	6,744	2,695	450	450

Note

- The height is measured from the bottom of the heat exchanger.
This value does not include the height of the foundation and the vibration-absorbing pedestal.
- All of the chilled water and cooling water connection flanges are of ANSI 150lb.
- The water pipe facility shall be designed to prevent external force to the chiller.
- The minimum spaces shall be provided around the chiller as follow :
 - Length direction of the chiller: 1,500 mm-2,000mm
 - One of the left and the right side shall be provided with space for Tube replacement.(3,700-6,700mm)
 - Control panel : 1,500mm
 - Inverter panel: 2,000mm
 - Height : 1,000mm
- All specifications are subject to change without notice.

Control panel outline

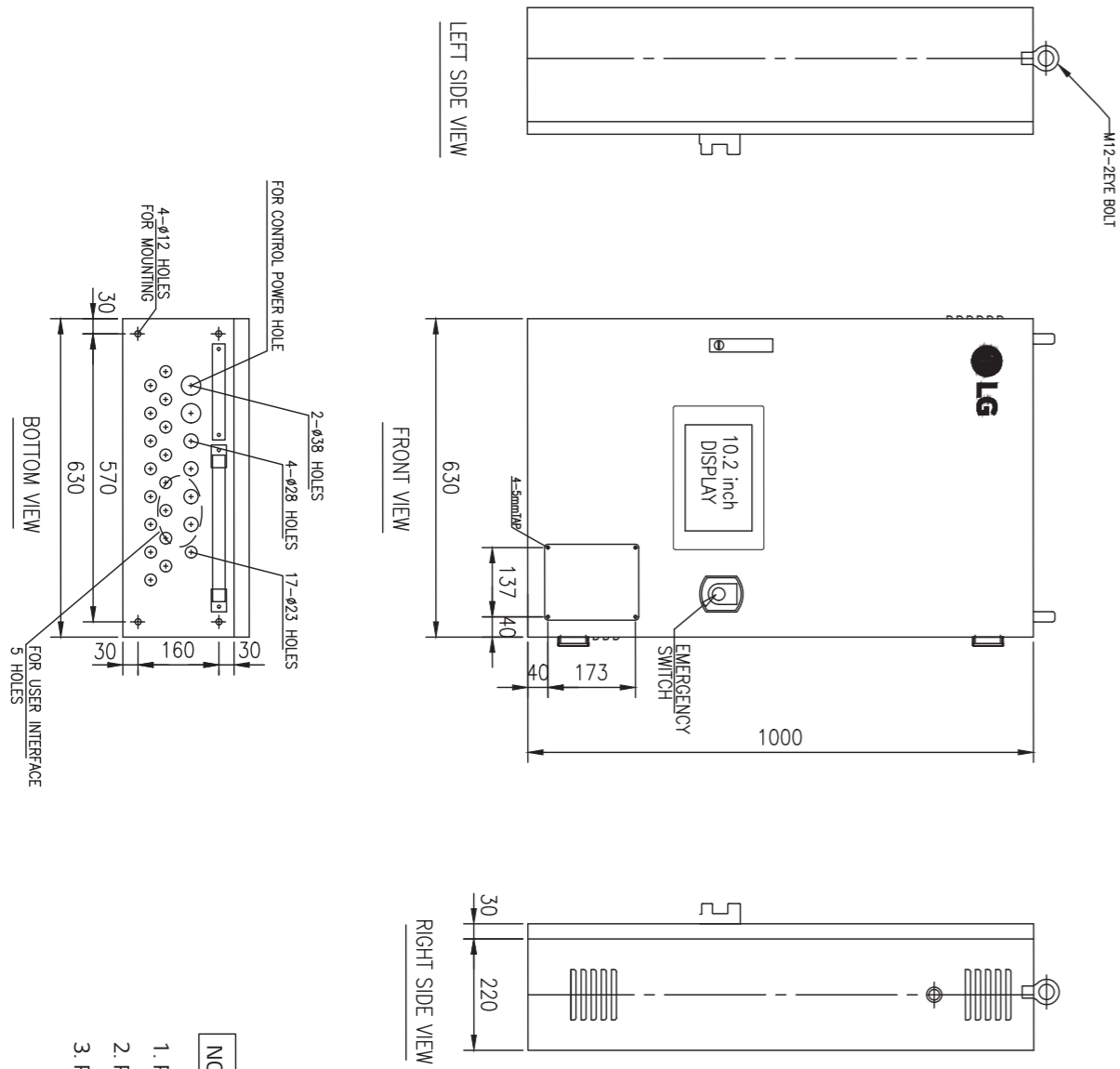

NOTE

1. PAINTING COLOR : WARM GRAY
2. PANEL THICKNESS : SPHC 2.0T
3. PROTECTION GRADE : IP41

Vibration isolation

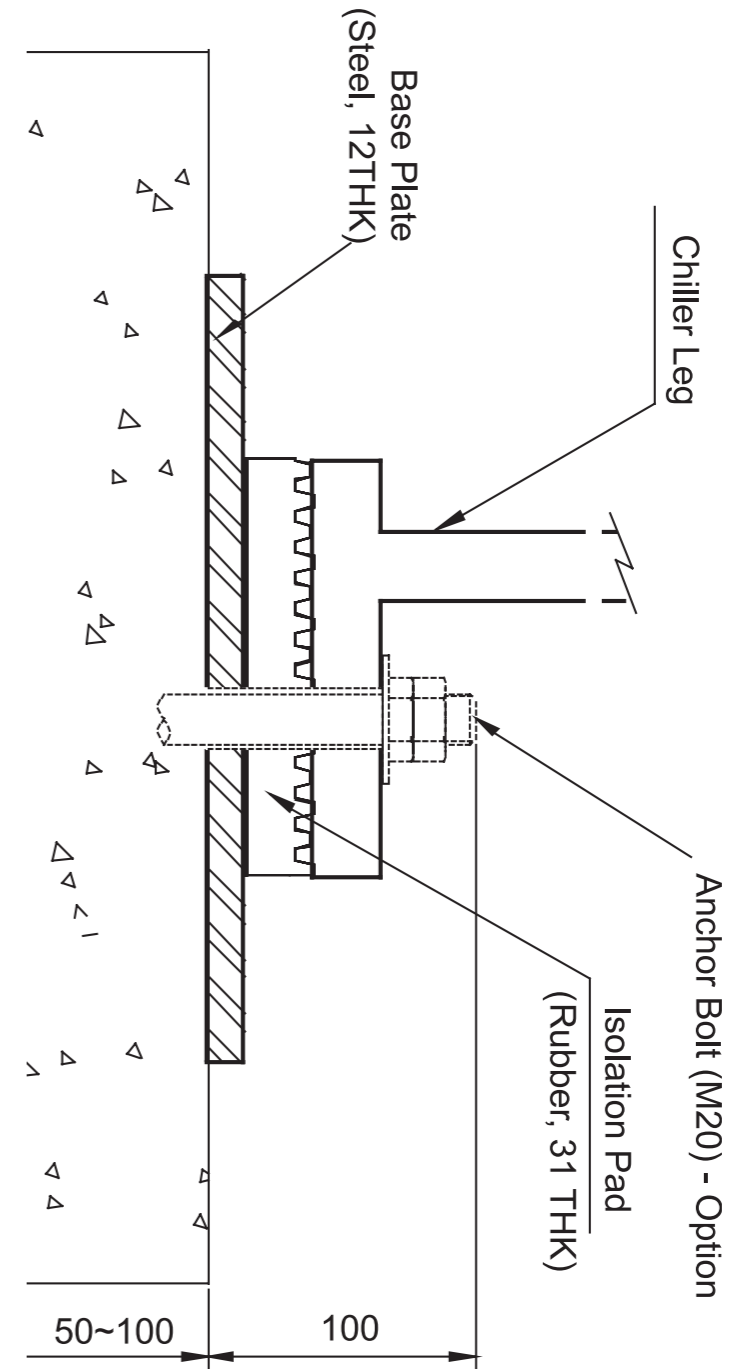

- Notes:
1. Unit is in millimeter
 2. As a standard isolation package, Base plate, Isolation pad and Level plates are supplied.
 3. Foundation height is recommended for piping and drain.

1 Compressor

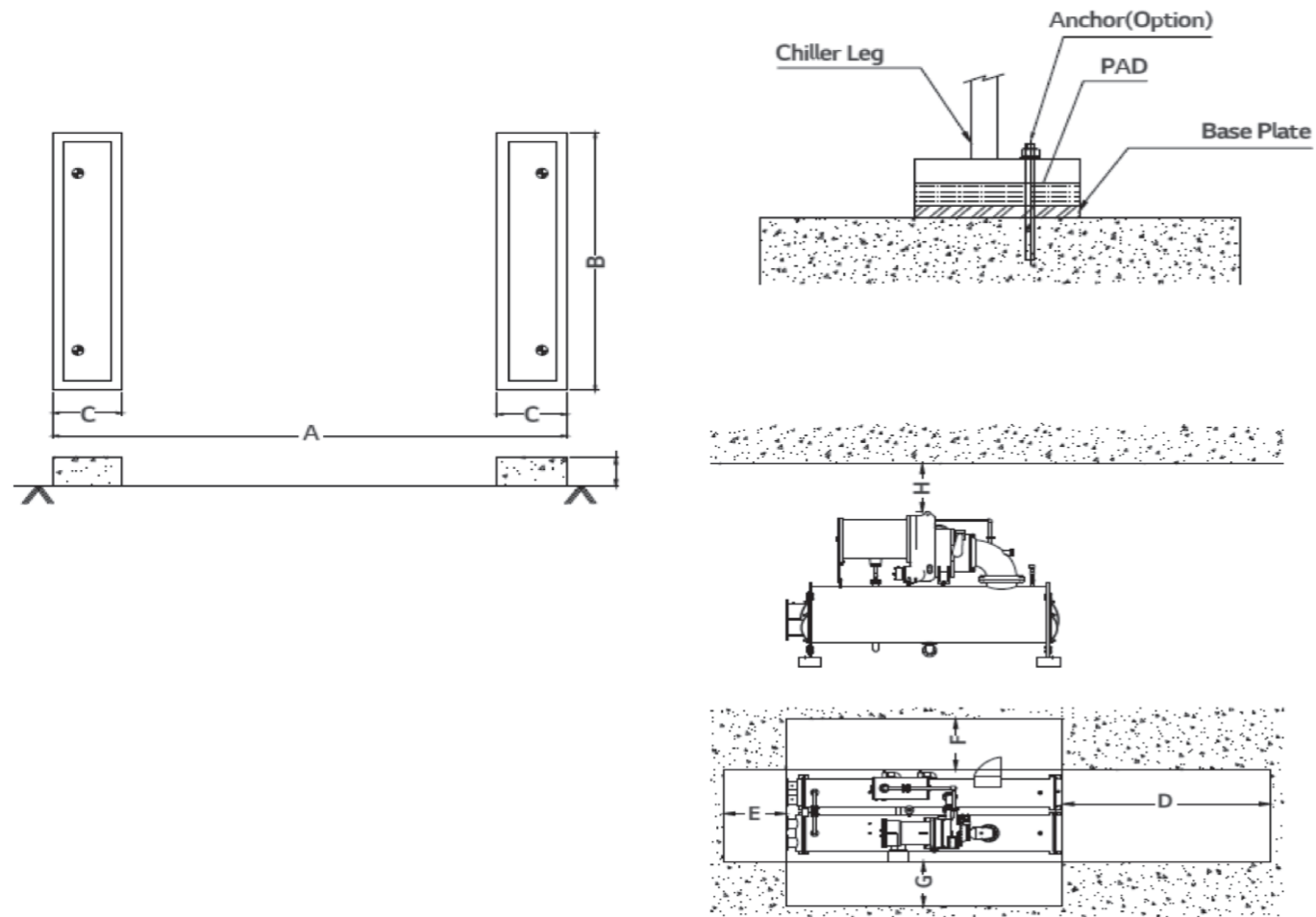

Note:
 D : Minimum needs space of exchanging tube
 F : Minimum needs space of control panel side
 H : Minimum needs space of top

Model		A	B	C	D	E	F	G	H
RCWFL	AL-AP	3,400	1,750	400	3,100	2,000	1,500	1,500	1,500
	BM-BP	3,400	2,000	400	3,100	2,000	1,500	1,500	1,500
	CM-CP	3,400	2,200	400	3,100	2,000	1,500	1,500	1,500
	DM-DQ	4,050	2,500	400	3,800	2,000	1,500	1,500	1,500

2 Compressor

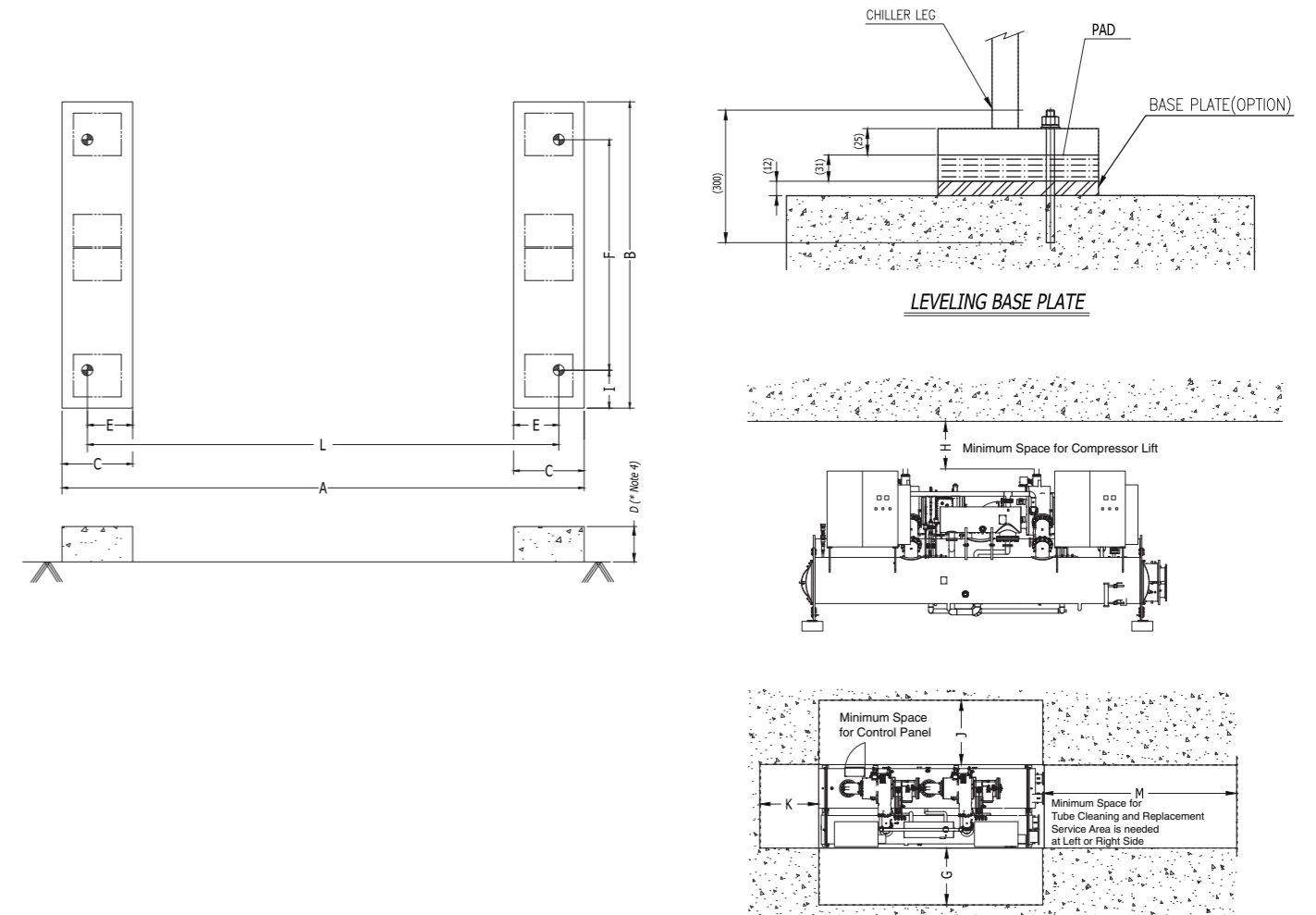

SERVICE SPACE

Model		A	B	C	D	E	F	G	H
RCWFL	AR-AW	4,880	2,000	400	4,600	2,000	1,500	1,500	1,500
	BT-BW	5,400	2,200	400	5,100	2,000	1,500	1,500	1,500
	CT-CW	6,400	2,500	400	6,100	2,000	1,500	1,500	1,500
	DT-DX	6,944	2,800	400	6,600	2,000	1,500	1,500	1,500

Interface wiring diagram

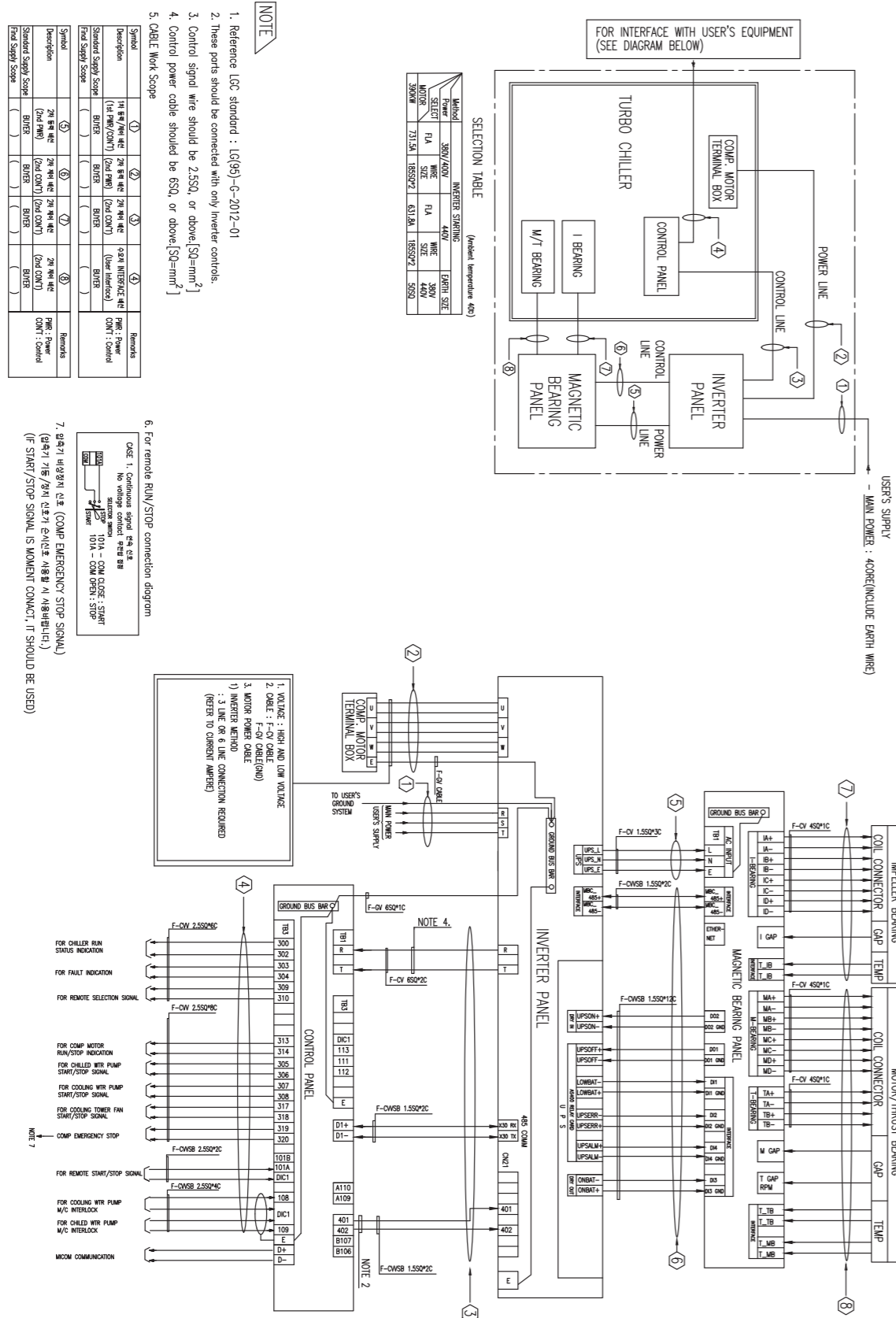

NOTE

1. Reference IEC standard : IEC(95)-0-2017-01
2. These ports should be connected with only inverter controls.
3. Control signal wire should be 2.550, or above. [SQ=mm²]
4. Control power cable should be 650, or above. [SQ=mm²]
5. CABLE Work Scope

6. For remote RUN/STOP connection diagram

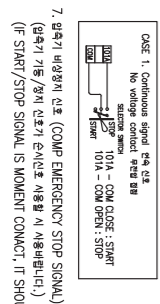

7. 緊急停止用ケーブル (COMP EMERGENCY STOP SIGNAL)
 (緊急停止用ケーブルの断線は、緊急停止を発生させない。) (If START/STOP SIGNAL IS MOMENT CONTACT, IT SHOULD BE USED.)

Notes: 1. Only for high voltage starter panel (3,300V, 6,600V).
 2. Control panel wire should be 2.0mm² or above and control power cable should be 5.5mm² or above.
 3. For other details, refer to certified Schematic Diagram.

Starter diagram

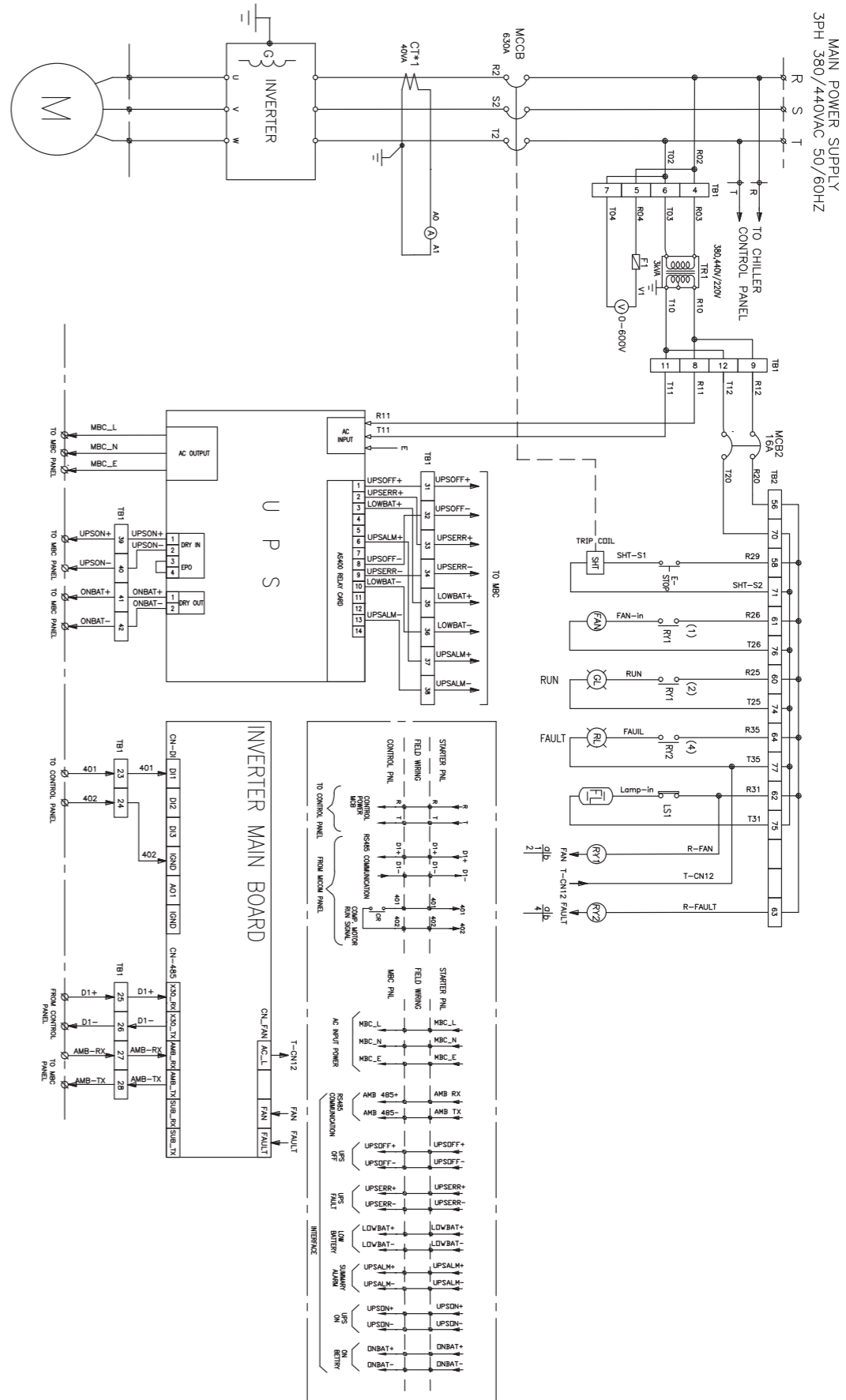

Schematic diagram

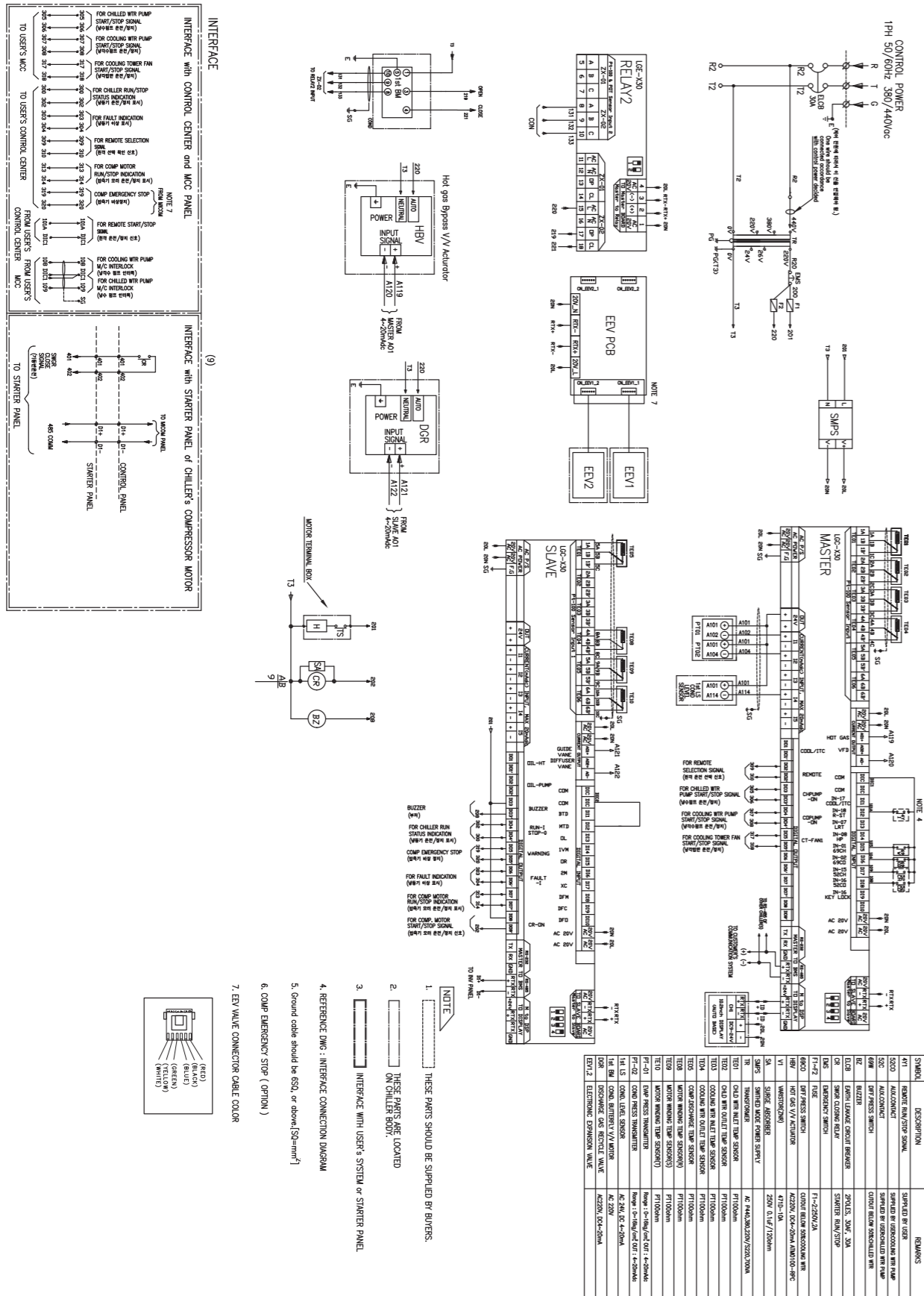

Chilled / cooling water piping

- As a standard, 10kg/cm² of flange is adopted for evaporator and condenser nozzles.
- The inlet nozzle is located on the lower side and the outlet is positioned on the upper side as a standard.
- All piping should be supported independently in order not to convey any stress and vibration onto the Chiller and have sufficient space for maintenance purpose.
- On each water box of evaporator and condenser, it is requested to install air-vent cock, drain valve and piping as well.
- It is strongly to install strainers on each inlet of evaporator and condenser in order to filter foreign materials. If the foreign materials are flowed into the heat exchanger, there is high possibility of freezing.
- It is recommended to install thermometer, pressure gauge and flow meter to measure the chiller operational condition.

Control of cooling water temperature

As a standard, 10kg/cm² of standard flange is adopted for evaporator and condenser nozzles. In general, if the atmospheric temperature falls below than design the temperature of condition cooling water from the cooling tower decrease as well. Therefore, for whole-year-operation chillers, it is strongly recommended to control the cooling tower fan according to outlet temperature of cooling tower and adopt by-pass system in parallel. The by-pass system is positioned on the outlet of cooling water and bypass the cooling water through 3-way control valve working at condensation pressure.

The 3-way control valve can be alternated with 2 units of butterfly valve. The system should maintain min. 14°C of temperature difference between cooling water outlet and chilled water outlet.

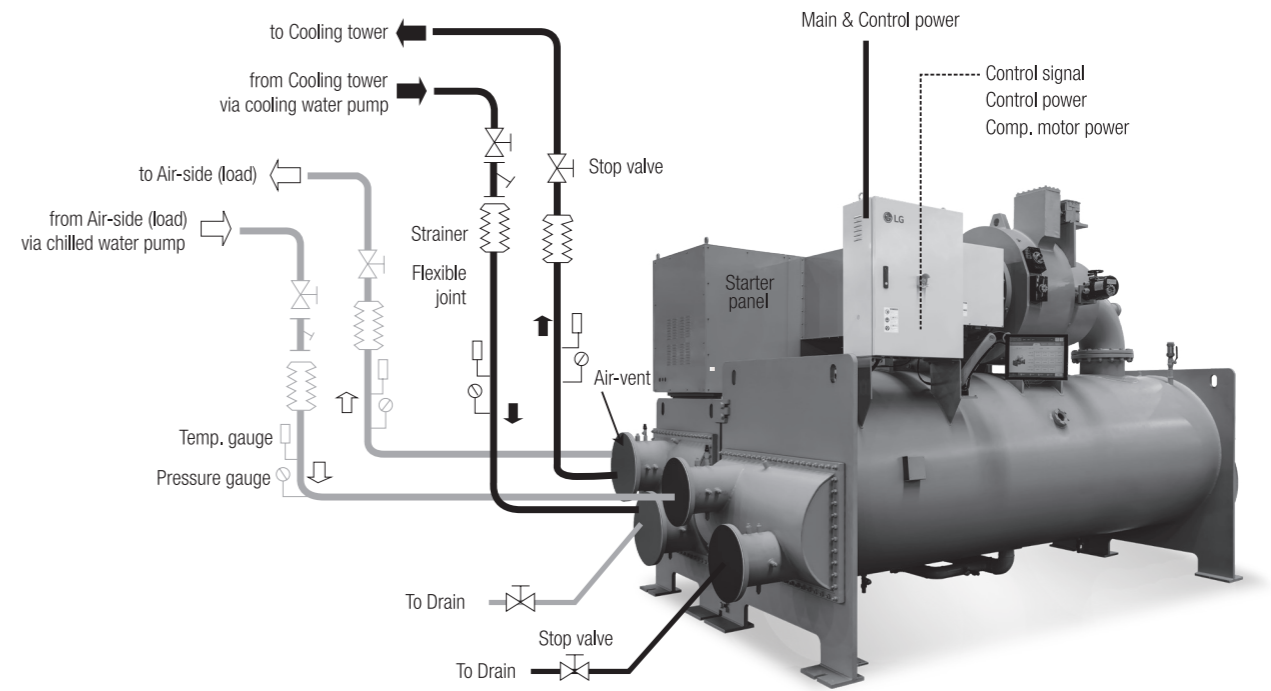

Notes: 1. Control power - 3Phase/220V/50Hz(60Hz) - should be provided by the customer apart from main power source.
2. The Main power wiring to the starter and 2nd wiring between the chiller and starter must be done based on local regulation. And the work scope is purchaser's.

Guide specification

Oil-free Magnetic Bearing Centrifugal Chiller RCWFL Series (Oil-free, Magnetic, HFC-134a)

Contents

1. Range of application
2. Special specification
3. Equipment specification
4. Range of construction
5. Range of supply
6. Warranty and Services
7. General terms



Guide specification



1. Range of application

This specification applies to centrifugal chiller models which are supplied for high efficiency, 2-stage oil-free magnetic bearing with HFC-134a(RCWFL*) produced by LG electronics.

2. Special specification

- 1) Oil-free system without containing oil in refrigerants makes improve heat exchange rate.
- 2) Highly efficient 2-stage refrigerant cycle(Economizer installed) saves energy
- 3) VSD application make lower peak current than any other starter.
- 4) Capacity is controlled by VSD and 1st / 2nd IGV.
- 5) Additional point for LEED conditions should be met refrigerant charge amount per capacity(kg/RT) within 1.38.
- 6) LG electronics can design the optimum condition of compressor for customer needs due to core technology of impeller design.
- 7) LG electronics can repair and maintenance magnetic bearings and VSDs by itself due to having technology of design and manufacture of magnetic bearings and VSDs directly.

3. Equipment specification

3.1 System configuration

- 1) High efficiency Centrifugal Chiller should be designed with 2-stage refrigerant cycle and IGV(Inlet Guide Vane) which is applied in front of impeller for stable operating at low load.
- 2) Compressor by motor direct drive system doesn't need a multiplying gear and it is applying oil-free magnetic bearing.
- 3) Economizer installed externally can segregate gas from liquid for operating 2-stage cycle.
- 4) The refrigerant cycle must be configured to achieve high efficiency at full load and partial load due to liquid refrigerant level precisely controlled by Gravity type variable expansion device in the economizer and by liquid refrigerant level control unit in condenser using modulator.
- 5) Additional point for LEED conditions should be met refrigerant charge amount per capacity(kg/RT) within 1.38.

3.2 Performance and Quality

- 1) The product shall meet the performance requirements of the AHRI(Air Conditioning, Heating and Refrigeration Institute) 2011 Standard 550-590 / 551-591.
- 2) Refrigerant should be environment friendly refrigerant HFC-134a with zero ODP.
- 3) Pressure vessel should be designed, manufactured and inspected in accordance with KGS Code(High Pressure Gas Safety Control Act) or ASME SEC.VIII(Optional) or PED (Pressure Equipment Directive), and certifications from the relevant authorized institution shall be achieved.

3.3 Product specification

3.3.1 Product configuration

Chiller unit consists of compressor(Including motor and magnetic bearing), Pressure vessels(Evaporator, Condenser and Economizer), liquid Refrigerant level and flow control device, refrigerant piping, control panels, VSD and safety devices. Also, it consists of cold insulation & vibration-proof devices.

3.3.2 compressor(Including motor and magnetic bearing)

- 1) The compressors are semi-hermetic high efficiency centrifugal type for HFC-134a, and the impeller should be made of special aluminum alloy with high strength and aerodynamic shape to minimize the efficiency loss.
- 2) The inlet guide vane which controls the capacity of the system, must have a structure with multiple vanes to minimize the flow loss at the inlet of the compressor.
- 3) Compressor is a motor direct drive type that does not need a multiplying gear and magnetic bearing which does not need oil supply for lubrication shall be applied.
- 4) The motor shall have semi-hermetic liquid refrigerant cooling system and the outside should be insulated with thermal insulation to prevent condensation. The motor shaft must have a highly stable structure with both ends support and the motor should incorporate with motor winding temperature sensors so that it can be monitored by the control panel in real time during operation.
- 5) Bearing shall be equipped with magnetic bearing type so that structure don't need lubrication by oil, auxiliary ball bearing shall be installed for supporting shaft during off condition of compressor.
- 6) Rotating speed of impellers shall be automatically controlled to adjust compressor capacity during partial or full load.
- 7) The efficiency of the chiller is improved by introducing 2-stage cycle with economizer.
- 8) A UPS(Uninterruptible Power Supply) is installed as a basic specification to prevent damage from the bearings by supplying electric energy stably even in case of power failure and filtering fine signals to bearings during operation of compressor.
- 9) It is possible to always check vibration level of shaft in the control panel in real time, so that the consumer can directly check the soundness of the compressor.
- 10) Magnetic bearing controller has separate storage devices so compressor Trip or critical phenomena that occur during abnormal operation can be confirmed later and swift action would follow.

3.3.3 Pressure vessel(Evaporator, Condenser, Economizer)

- 1) Evaporator and condenser shall be equipped with Shell & Tube structure. A high efficiency machined tube shall be applied, and the heat transfer tubes shall be assembled by mechanical expansion on the tube sheet and they can be

- removed during maintenance & service.
- 2) The evaporator shall be equipped with perforated plate with less than 10mm holes, which makes uniform distribution of the liquid refrigerant in front of inlet pipe.
 - 3) The condenser shall be equipped with an anti-collision plate at the inlet of the gas, which prevents tubes from direct impact by gas jet from compressor discharge pipe.
 - 4) The tubes are manufactured with machined grooves inside and outside tube surface to enhance the heat transfer performance, and shall have non-machined surfaces at position where tube sheet and tube supporter contact with each other. The tube supporter shall be designed in accordance with the TEMA and ASME standards and shall be of a structure capable of supporting the tube stably.
 - 5) Pressure vessels shall be designed, manufactured and inspected in accordance with KGS Code(High Pressure Gas Safety Management Act) or ASME SEC.VIII(Optional) or PED(Pressure Equipment Directive), and certifications from the relevant authorized institution shall be achieved.
 - 6) Safety valves should be installed on top of the evaporator and condenser in accordance with KGS Code(High Pressure Gas Safety Management Act) or ANSI / ASHRAE 15 Safety Code(Optional).
 - 7) Water box shall be designed to be able to select 10kg/cm², 16kg/cm², 20kg/cm² according to the water pressure, and the structure should be able to do the air vent in the upper part and drain in the bottom. In case of water box for 16kg/cm² and 20kg/cm², it should be a rigid structure that ensures sufficient strength and reliability even under high pressure.
 - 8) Economizer shall be installed externally and liquid and gas refrigerant should be completely separated inside.

3.3.4 Refrigerant level and flow control device

- 1) Refrigerant level control device installed in condenser shall be controlled by Micom and economizer shall be equipped with a gravity type variable expansion device in order to maintain the optimum refrigerant level for every cycle at full load and partial load.
- 2) The liquid refrigerant level control sensor installed in the condenser is provided with a shut-off valve for easy service and maintenance, so that it shall be possible to replace service parts without extraction of refrigerant.

3.3.5 control panel

- 1) Configuration of control panel
The control panel consists of a Micom module(Main module, input / output module, display and operation keys or touch pad module), power supply for supplying stable power, and breaker, magnetic contactor and control relay, etc.
- 2) Main module
High-performance microprocessor is applied to perform control functions optimized for chillers. A high degree of

A / D(Analog / Digital) converter shall monitor the values of various temperature sensors in real time and display them on the screen or apply them to the control. In addition, RS-485 / 232c communication port is built in as standard to support customer's remote monitoring control. RS-485 or RS-232c can be selected and used by simple operation so that customers can easily respond to building automation.

3) Display and touch pad module

3-1. Display and touch pad module comprises an input section and a display section. Input section is composed of various operation data, setting values for machine operation, and a touch for inputting various data or selecting a menu and display section shows the abnormal data, mechanical operation / stop state important for machine operation, compressor operation, cold water / coolant flow, abnormal status, the condition of RPM manual operation selection, the condition of variable diffuser manual with the characters and the LED lamp. Especially, it is necessary to improve the convenience of the operator by directly touching and manipulating the operation equipment frequently used by the operator.

3-2. Touch pad shall provide easy operation and monitoring by configuring the character display and menu selection buttons on the display. The display should also be capable of indicating the operating conditions such as cold water, coolant inlet / outlet temperature, compressor discharge temperature, motor bearing temperature, condenser pressure, evaporator pressure, operating current, motor RPM, variable diffuser opening and refrigerant valve opening, etc. by selecting Korean, Chinese and English.

3-3. In case of ARM type

The display and control unit is connected to the outside of the control panel, and the controller of the module is located inside the control panel. Other display and operation are the same as those of the basic controller.

3-4. Input/output module

In case of Input/output module, the module shall consist of a digital input part for checking the operation status of various switches and a digital output part for controlling the operation of the machine. The input / output section is equipped with a photo coupler for blocking various noises. It is required to transmit and receive all data to and from the main module by communication, so that it is necessary to prevent malfunction caused by electromagnetic waves generated when data is transmitted / received by a general cable.

3.3.6 control function feature

- 1) Convenient operation data management
Large graphic LCD(Korean 16 characters* 13 lines) was used to check many operation information simultaneously on one screen. Also it can record analog data(Temperature data, for example) 200 times for each channel and 300

times for operation and error history(eg operation, stop) at the time interval set by the customer. In addition, the trend of temperature and operating current change can be easily grasped by graphing the cold water outlet temperature and the compressor motor operating current in real time.

2) Self-diagnosis and error record storage

The micom monitors the status of the machine during machine stop or operation and informs the operator by text, alarm lamp and buzzer. At the same time, fault time and fault data are automatically stored and used conveniently during maintenance. In particular, the type of fault is classified as a warning and a fault. If the warning is generated, the contents of the warning should be displayed as letters and operation should be continued to minimize unnecessary machine stoppage.

3) Chillers must be controlled by applying an optimized artificial intelligent control algorithm as follows

- Soft start
The VSD frequency should be gradually controlled to prevent mechanical impact such as surging caused by a sudden increase in load at start-up.

- Digital PID control

The digital PID control combined with soft start automatically recognizes the optimal PID control point when the operation mode is changed automatically at start-up or manual operation and reflects it to the control formula so as to minimize unnecessary machine stop and ensure stable and precise temperature control.

- Preventive operation

Measure the temperature and pressure of each part in operation in real time and execute the first and second preventive operation according to the result. Prevent stopping chiller due to overload, high pressure of condenser or low pressure of evaporator.

- Schedule operation function

It is convenient to operate the equipment by applying the schedule operation function which can select run / stop and control temperature set value by day of the week, holiday, or 11 times a day.(Reservation operation)

- Service function

Supports the following service functions to facilitate maintenance.

- * Automatic setting of sensor to automatically set each sensor with software

- * Cooling tower fan step control function for stable cooling water temperature(VSD control function is optional)

- * Displays the number of times of operation of pump and motor attached to the main body and the total operation time

- * Print function to print operation or abnormal data(Optional)

4) Powerful customer support features

- Help function
If a fault occurs, the fault messages are saved in memory,

and if the driver selects the menu in accordance with the fault details, explanation of the fault remedy method can be seen for convenience of operators

- Communication function for building automation and remote monitoring control
MODBUS™ / RS485 is equipped as a communication function with standard for convenient connection with customer's monitoring system. It provides non-voltage input / output for simple remote operation / stopping using electrical wiring or for monitoring machine operation. In addition, BACnet™ and Ethernet can be installed and used as an option.

5) Display lamp image

All displays are indicated by letters on the LCD and the indicators are set in the following eight situations

- Chiller operation / stop
- Compressor operation
- VSD normal
- Bearing surfacing
- Cold water flow normal
- Cooling water flow normal
- Vain manual
- RPM manual

3.3.7 VSD

1) It is attached to the top of the product with the body attachment type.

Soft starter and converter, VSD, main board, fan SMPS, communication connection board are built in. It must be connected to the outside via the power input terminal, motor output terminal, and communication connection terminal. Self-diagnosis is possible with built-in microcomputer, so it detects H / W fault(IGBT module error, sensor error) and S / W fault(input part, IGBT module part, thyristor module part, VSD drive error). VSD control must be possible with Modbus 485 communication and contact control.

2) H/W Fault

Detects IGBT module and sensor abnormality.

- IGBT module part abnormal : electric current abnormality (IGBT module trip stop)
- Sensor abnormal:CT sensor offset abnormality,DC voltage sensing part abnormal

3) S/W Fault

S/W Fault notice inlet part, IGBT module part, thyristor module part, VSD operation abnormal.

- inlet part: inlet part current detection
- IGBT module part: electric current abnormality(Over current/ overload protection control), temperature abnormality(high temperature protection function)
- Thyristor module part: temperature abnormality(high temperature protection function)
- VSD operation abnormal: voltage abnormal(DC-LINK overvoltage/low voltage protect control)

3.3.8 Safety device

- 1) Cold water low temperature [cold water outlet side temperature sensor]_ evaporator freeze protection
 - 2) Evaporator low pressure [evaporator pressure sensor] _ Chiller protection In case of abnormal low pressure of evaporator
 - 3) Condenser high pressure [condenser pressure sensor] _ Chiller protection in case of abnormal high pressure of condenser
 - 4) Motor high temperature [motor temperature sensor] _ motor protection in case of abnormal winding temperature rising
 - 5) Cold water abnormality [cold water abnormal interlock] _ chiller protection in case of abnormality cold water pump
 - 6) Cooling water pump abnormality [cooling water pump interlock] _ chiller protection in case of abnormality cooling water pump
 - 7) Cold water flow rate abnormality [cold water differential pressure switch] _ chiller protection in case of abnormality cold water flow rate
 - 8) Cooling water flow rate abnormality [cooling water differential pressure switch]_chiller protection in case of abnormality cooling water flow rate(Optional)
 - 9) Surge abnormality [control board] _ compressor protection in case of abnormal surge
 - 10) Motor/inverter over current _ electrical motor/inverter chiller protection in case of over current
 - 11) Safety valve [evaporator/condenser] _ Refrigerant release to protect the chiller in case of abnormality high pressure
 - 12) Current limiting function [control board] _ operation current limiting operation for compressor protect
- * The temperature of the cooling water should be adjusted so that the temperature difference between the cold water outlet and the cooling water outlet is at least 14°C.

3.3.9 vibration-proofing device

Standard specification is a sandwich type vibration-proof pad made of rubber and cork. If the structure supporting chillers can easily be resonated by the chiller vibration, the vibration-proof spring must be supplied(Optional).

3.3.10 Thermal insulation

- 1) Thermal insulation Standard Specification is NBR material of 19mm or more in thickness and KS or equivalent standard products are to be applied. However the thickness can be designed and applied to prevent of condensation by customer's requirements and conditions of use.
- 2) Thermal insulation part : evaporator, motor for compressor, chilled water box etc.(According to thermal insulation work)

3.3.11 Commissioning

LG engineers or equivalent engineers shall provide start-up & commissioning and operating education.

4. Range of construction

Items	Supplied By	Notes
Painting	LGE	Body : Morning Gray Startup Panel : Warm Gray control panel : Warm Gray
Cold insulation	LGE	Cold-insulate the external side of evaporator, chilled water box, and motor. The material is NBR of 3/4"(19mm) and its color is black.
External piping	Customer	External piping work for chilled water, cooling water and drain
Control system wiring (on the secondary side)	Customer	Control wiring between the starter panel and the control panel
Power system wiring (on the secondary side)	Customer	Power and ground wiring between the chiller and the starter panel
Control power	Customer	Control power of 3ph, 380V shall be supplied to the starter panel.(Minimum power capacity: 4kVA)
Building and foundation	Customer	Completing the foundation construction prior to installing the chiller
Interlock wiring of the chilled water pump and the cooling water pump	Customer	Wiring between the control panel and the pump control panels
Relief valve vent piping	Customer	Piping for discharge of refrigerant in emergency

5. Scope of supply

Items	Supplied By	Notes
Centrifuge chiller body	LGE	Refer to the body components
Refrigerant (R-134a)	LGE	Delivery with refrigerant charged (Divide or deliver separately if required)
Lubrication oil	LGE	Delivery with oil charged or separate delivery with chiller
Isolator Pad	LGE	Vibration absorption pad
Spare parts	LGE	Provide spare parts as on option if customer is required
Chiller manual	LGE	Installation and operation manual
Leveling plate	LGE	Parts for leveling the centrifuge chiller
Starter panel	LGE	Compressor motor starter (Customer may select)

6. Warranty & Service

- 6.1 The warranty period of the product shall be either "1.5 years after delivery of the product" or "1 year after trial run", whichever comes first.
- 6.2 In case of failure due to mechanical parts, materials and work defects during the warranty period, repair is free of charge if the defect is recognized after the investigation by LG Electronics.
- 6.3 LG does not guarantee the free repair of a product in the following cases.
 - 1) In case of trouble after repairing outside of the designated store

- 2) In case of malfunction caused by the user's fault clearly in use and handling
- 3) In case of resale or transfer elsewhere during warranty period
- 4) In case of fire or natural disaster

7. General terms

- 7.1 Before production of the chiller, all matters concerning the production should be submitted and approved to the contractor. Items not indicated in this specification shall be approved after consultation with the contractor.
- 7.2 You must inform LG Electronics when resale or transfer of product to other before disposal.